

WATTS® 150 YEARS

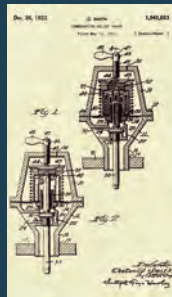

The Watts Way

Fourth Edition
David Lyon & Ned Berube

TABLE OF CONTENTS

CHAPTER ONE	
THE EARLY DAYS: 1874-1918	04
CHAPTER TWO	
A FAMILY BUSINESS, A NATIONAL FOOTING: 1918-1945	16
CHAPTER THREE	
GROWING WITH AMERICA: 1945-1959	28
CHAPTER FOUR	
THE ADVENT OF PROFESSIONALISM: 1959-1972	40
CHAPTER FIVE	
NEW PRODUCTS, NEW DIRECTIONS: 1972-1978	54
CHAPTER SIX	
SETTING THE STAGE: 1978-1984	64
CHAPTER SEVEN	
WATTS INDUSTRIES ACQUISITIONS: 1984-1993	78
CHAPTER EIGHT	
BUILDING A BILLION-DOLLAR COMPANY	92
CHAPTER NINE	
FAST-FORWARDING TO THE NEW MILLENNIUM: 1994-1999	100
CHAPTER TEN	
SPINNING OFF THE INDUSTRIAL, OIL & GAS BUSINESSES: 1999	106
CHAPTER ELEVEN	
BACK TO THE FUTURE AS A BILLION-DOLLAR COMPANY: 2000-2004	110
CHAPTER TWELVE	
GROWING & SUSTAINING WATTS' GLOBAL LEADERSHIP: 2005-2013	132
CHAPTER THIRTEEN	
TRANSFORMING WATTS FOR THE FUTURE: 2014-2019	142
CHAPTER FOURTEEN	
WATTS PREPARES TO TURN 150: 2020-2023	156



CHAPTER ONE THE EARLY DAYS: 1874-1918

When Joseph Edwin Watts arrived in America, he found a country engaged in a spirited expansion of its western territory and its eastern industrial base. From an Old World point of view, America was a heroic land where a man could make his own mark, profit by his talents and carve out a future of his choosing.

Watts was among the first of a group of workers who would remake New England's powerhouse textile industry in Lawrence, Massachusetts, a new town that had been built on faith in American ingenuity to harness more effectively the immense power of the Merrimack River for modern industrial production. Earlier success in capturing the river's water power had led to the founding of Lowell, Massachusetts, in 1826, which by 1840, was the showpiece of the American textile industry. It was in Lowell that the water turbine was invented — a device that was far more efficient than the old water wheels in translating the energy of falling water into the rotary power used throughout the mills.

In 1845, a group of industrialists, investors and mill owners formed a corporation to establish an industrial

center, Lawrence, where no community had existed before. They planned to create immense artificial falls by damming the river, an idea that had been considered for decades and for which the Lowell waterworks experiments had finally provided the engineering experience to turn the dream into a reality. The adjoining countryside was to be called "New City," and their engineering feat was to be known — in keeping with the optimistic terminology favored by the pragmatic men behind this money-making venture — as "The Great Stone Dam." The Essex Company, as the group was known, created a plan for its New City that included an independent machine shop, which in a way, was the forerunner to Joseph E. Watts' later enterprise. To deliver the water from its great dam, the group also constructed the Northern Canal. The canal was a simple trench compared to the elaborate waterways of Lowell, but the dam, of an untried design and scale, was a mighty enterprise, calling on the best engineering minds of its day. Begun in September 1845 and rising 36 feet straight up from the bedrock beneath the riverbed, the Great Stone Dam ran the breadth of the Merrimack River for more than 900 feet and took exactly three years to complete.

Opposite: The completion of the Great Stone Dam at Bodwell's Falls in 1848 was one of the greatest engineering feats of the age.



Joseph E. Watts emigrated to Lawrence, Massachusetts, in 1857 at just 17 years of age. The records listed his occupation as “machinist,” and it is likely that he had just completed an apprenticeship in that trade in his native city, Cheshire, England.

Even before the Great Stone Dam was completed, a cofferdam began to divert water to the industrial canal. On March 18, 1848, after nearly three years of work and a combined investment of more than \$2 million in waterworks, Lawrence's first mill, the Bay State Mills, finally creaked into action. It was a momentous occasion: the birth of an enterprise and a city in one. In short order, the town of Lawrence became a growing concern. From a district of 150 people living amid sand hills and river marshes in 1845, the town grew to a population of 12,147 by 1853.

But the promise of Lawrence, which had seemed so bright when the Essex Company launched its ambitious project in 1845, was soon dimmed. By the time

the mills began to make cloth, the U.S. was in the midst of a depression. Just when the capacity for producing textiles was expanding, the demand for them was drying up. Moreover, the depressed national economy increased the tensions between the North and South. Cotton prices were beginning to drop on the world market, and the cotton growers believed they could not survive with a paid labor force. In April 1861, a powder keg exploded at Fort Sumter, North Carolina, and the nation erupted into war.

The Civil War years, 1861-1865, and their aftermath were a difficult time for the mills of the Merrimack. They depended on a steady flow of cotton from the plantations in the South, and

business slacked off after an initial rush of orders for cloth to make uniforms. Also, in the politically tumultuous years just before and after the Civil War, New England received successive waves of immigrants. The world had changed, and a market economy prevailed. Fresh labor stocks available from every boat that docked from Europe meant lower wages and an increasing social polarization in every city of the region. Just as relations among the ethnic enclaves of America's new industrial cities grew ever more strained, so did the relations between mill owners and workers. When the Panic of 1873 plunged the national economy into another depression, mill profits declined and conditions worsened in the tenements and boarding houses of the factory towns.



In 1847, the state legislature passed a bill separating Andover and Methuen, creating a new district. Concurrently, the Essex Company, made up of merchant and industrial families who had also built Lowell, named this new district Lawrence, after the Lawrence brothers who owned 20% of the company's stock.



Joseph E. Watts chose the Pacific Mills in which to work in 1857. It was common practice in the 19th century to recruit skilled workers from England because many of the leading engineers in the textiles and waterworks industries were themselves English immigrants.

After a brief move to New Hampshire in 1867, Joseph E. Watts had settled in at the Pacific Mills as a machinist. In Watts' era, a machinist was a mechanical jack-of-all-trades — machinists fabricated metal parts, adjusted and repaired the mill machinery, performed plumbing tasks and oversaw the great boilers used to produce steam for processing wool. But Watts proved he had a head for learning new skills. His 1894 obituary in the Lawrence Daily American observed, "When Mr. Watts came to Lawrence he was a machinist but during his stay here he had learned much and at the time of his death he was well known as a skillful brass finisher and iron manufacturer."

Joseph E. Watts was also an inventor and an entrepreneur, and when the time was right, he made his move. He chose to leave the employ of Pacific Mills in 1874. There is no existing record of his reasons for doing so, but it may be that with the nationwide depression, he preferred to create his own opportunities by going into business for himself.

Watts set up an independent machine shop on Essex Street in Lawrence, where he could contract to work for any or all of the mills. The business flourished, and in a period of great social and economic mobility, Joseph E. Watts shared in the growing wealth of the nation and social

stature of the American businessman.

From his first small shop on Essex Street, he moved his business to rented quarters on Methuen Street, then to a larger operation on Lowell Street. Finally, in 1893, Watts constructed a block-sized brick building across from his last rented quarters. A newspaper account in 1895, a year after his death, noted, "The building was planned for convenience and economy of operations. It was equipped with the latest up-to-date machinery and it is within bounds to say that it is the best built and most completely equipped machine shop in the limits of the city of Lawrence." By the time of his death, Watts employed five skilled machinists.



A view of Canal Street in Lawrence from the Boston and Lowell Railroad Bridge.



Joseph E. Watts achieved widespread fame in the manufacturing world as the patentee and maker of steam and water pressure regulators by advertising himself in local trade publications.

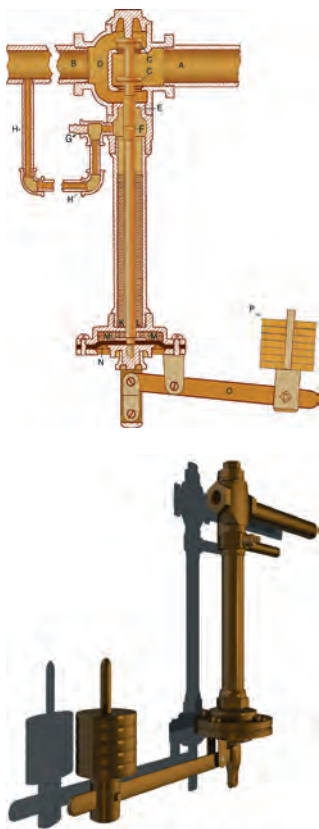

A cutaway drawing of the Watts Patent Slasher Regulator is an example of the creative simplicity of Joseph E. Watts' groundbreaking inventions.

The textile mills of Lawrence, for which Watts supplied products, were the most advanced and complicated manufacturing concerns in the mid-and-late 19th century and were physically among the largest of manufacturing plants. Their sheer size made them pioneers in industrial systems we take for granted today — automatic sprinklers, fire-protection pumping systems and large heating systems working off steam boilers.

In addition to his accomplishments as a machinist and entrepreneur servicing the textile industry, much of Watts' success lay in his inventiveness. Some time after 1881, Watts began to seek patent protection for his seminal innovations, mostly related to pressure-reducing valves, and before his death in 1894, he had received a total of 18 patents for valves needed by the textile industry.

Watts had managed to accomplish what individual inventors always dream of — he created a humble device that, although its earliest applications were in the textile business, proved essential to many other industries. The weaving machinery may have run on rotary motion supplied by water turbines, but other processes throughout the mills — hot-water heating systems, cylindrical dryers, bleaching and dye vats, hydraulic presses — required water or steam flow at low pressure. Wherever it was necessary to reduce and regulate water, steam or air pressure, Joseph E. Watts' reducing valves were essential. From the textile industry, Watts expanded to general industrial needs, including applications

where it was essential to maintain a vacuum — such as distillation and boiling down syrups and sugar — and to deliver a constant pneumatic pressure — as in mining and underwater operations.

The challenge of reducing and controlling steam and water pressure was complicated, but Joseph E. Watts had applied what engineers call an “elegant solution” — the most straightforward and least complicated approach. For example, the cutaway drawing of the Watts Patent Slasher Regulator (lower left) demonstrates the functioning of a valve to reduce inlet steam pressure of 20 pounds to an outlet pressure of 5 pounds. With this straightforward design, the operator simply had to slide the weights on the lever arm until they produced the desired steam pressure coming through pipe H. Thus, initially controlled by gravity, the steam and water pressure regulators solved fundamental problems wherever pressure reduction was required.

At the time of Watts' death, his company was selling steam and water pressure regulators to virtually every manufacturing concern in the Merrimack Valley. Because the region represented the cutting edge of the industry, manufacturers from other parts of the U.S., Canada and Europe visited to research the technology. And some of them installed and continued to order Watts' valves as part of their textile operations, which allowed the Watts Company successors to boast of international sales. In effect, Joseph E. Watts, the machinist from England, had planted the seed for a control valve industry.

Opposite: In 1874, Joseph E. Watts left Pacific Mills and set up an independent machine shop on Essex Street in Lawrence, where he contracted work supplying parts and fittings for machinery in the local textile mills.



FARMING TOOLS
AERONAUTICAL PIPES

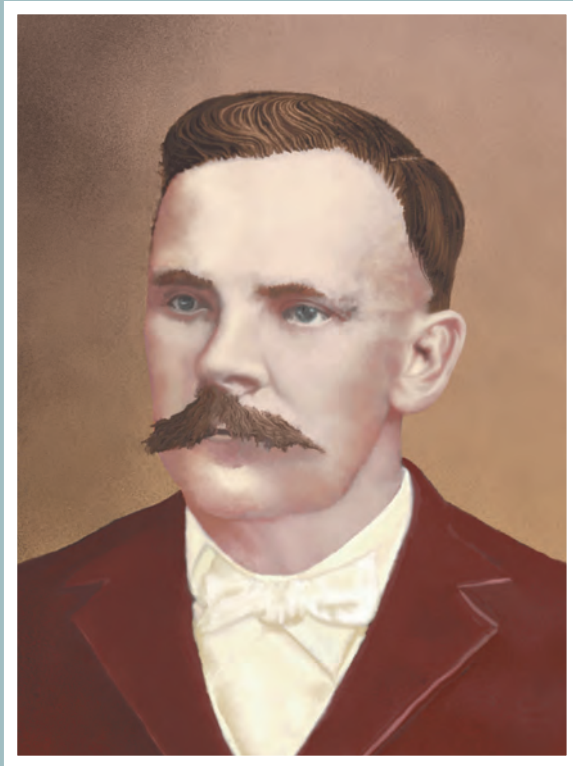

Robert F. Pickels, who had studied and taught at MIT, recognized the significance of Watts' accomplishments and purchased his company upon his death.



George W. Dodson, Pickels' partner in obtaining the Watts Regulator Company, was a prominent stovemaker and plumber who had been educated at Cornell University.

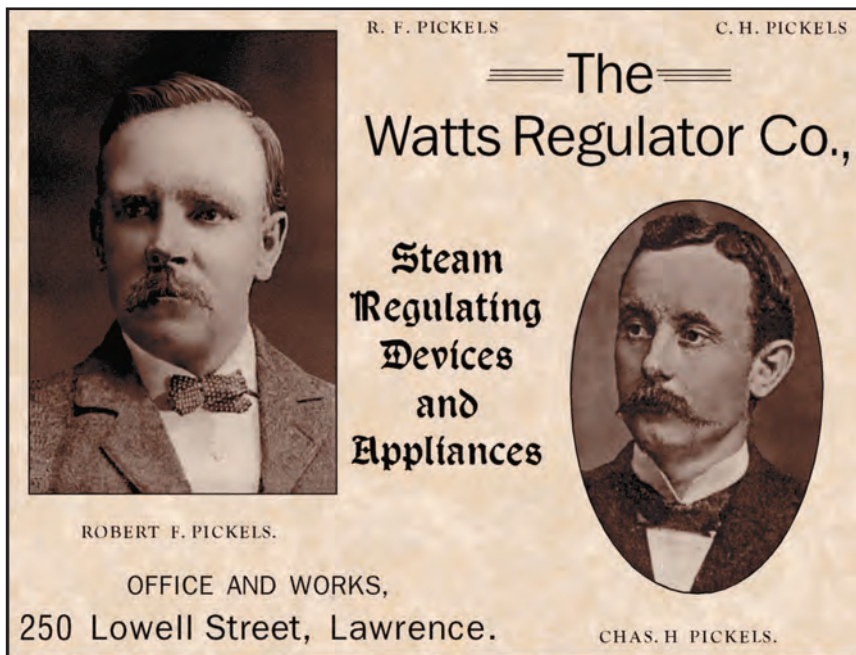

R. F. PICKELS C. H. PICKELS

== The ==
Watts Regulator Co.,

**Steam
 Regulating
 Devices
 and
 Appliances**

ROBERT F. PICKELS.

OFFICE AND WORKS,
 250 Lowell Street, Lawrence.

CHAS. H. PICKELS.



CHAS. H. PICKELS,
**Practical Plumber, Tin and Sheet
 Iron Worker.**

“SANITARY PLUMBING A SPECIALTY.”



**STOVES, RANGES AND FURNACES.
 KITCHEN FURNITURE OF EVERY KIND.
 OIL STOVES AT A BIG DISCOUNT.**

N. B.—The “VOLUNTEER” OIL STOVES from 75¢ to
 \$2.25—a stove that will give every satisfaction.

CHAS. H. PICKELS, - 427-BROADWAY-427

Together, Robert and Charles Pickels transformed Watts Regulator from a small local business to an enterprise supplying its specialty products to numerous industries.

The significance of Watts’ accomplishments was not lost on Robert F. Pickels, a Lawrence construction engineer. Pickels had overseen a machine shop employing 300 men and had worked as a draftsman and designer for the forerunner to the General Electric Company. Among his early accomplishments was the design of the electric motors that powered Boston’s streetcars. His partner, George W. Dodson, had dabbled in a number of enterprises. An advertisement for Dodson’s shop in the 1895 Lawrence semicentennial commemorative book indicates a flourishing plumbing and heating business.

“Plumbing and Heating of Homes a Specialty,” trumpeted the ad, “Agent for Richmond Steam and Hot Water Heaters.” In May 1895, for an unrecorded sum, Pickels and Dodson purchased the Watts business, patent rights, buildings and goodwill from Amelia Watts, Joseph’s widow.

Pickels’ technical acumen and Dodson’s practical abilities were a good match for the new company. By September, the pair had quadrupled Joseph E. Watts’ volume of business and had doubled the workforce, expanding to two of the three floors of the new building Watts had

erected in 1893, just two years earlier. Besides manufacturing iron and brass fittings and valves, the firm also made mechanical drawing, modelmaking and electrical construction part of its business.

But far and away, the leading product line was the Watts steam and pressure regulators and an unpatented line of steam boiler damper regulators. A newspaper account at the time listed 17 major manufacturers in New England using the Watts regulators “and thousands of others in this country and Europe.”



Watts Regulator's "commodious and well-equipped plant" on Lowell Street was heralded in a local newspaper article in September 1895.

GEORGE W. DODSON,
Plumbing and Heating of Homes a specialty.



Agent for Richmond Steam and Hot Water Heaters.
 Arlington and Richmond Ranges.
 TELEPHONE CONNECTED.

11 LAWRENCE STREET, LAWRENCE, MASS.

WATTS REGULATOR COMPANY,
(SUCCESSORS TO JOSEPH E. WATTS.)
Machinists AND Brass Finishers
 Lawn Mowers Sharpened, Bicycle Repairing, Steam Traps, Cocks and Faucets.
CARLMAN DAMPER REGULATOR.
 Watts Patent Regulator for Steam and Water.
252 LOWELL STREET, - - LAWRENCE, MASS.
 Telephone 349-3 **R. F. PICKELS, Manager.**

Early advertisements for both Dodson's plumbing and heating business and the Watts Regulator Company.

Sometime before the turn of the century, Dodson left the company and Robert Pickels brought his brother, Charles H. Pickels, into the business. Charles Pickels, like Dodson, was also a plumber and presumably brought with him the practical know-how to advise on the installation and operation of the Watts regulators. The driving force of the enterprise, however, appears to have been Robert, for there are only occasional references to Charles in the advertising and catalogs from the Pickels era. By 1911, Pickels had entered into sales agreements with representatives in Boston, New York, Chicago, Philadelphia, Baltimore, Charleston (South Carolina) and Montreal.

But Pickels also saw other opportunities looming. Joseph E. Watts had concentrated his operations on the needs of the textile industry, and the early years of Watts Regulator likewise focused on large industrial, municipal and institutional accounts. But by World War I, Robert Pickels was advertising his water and steam pressure regulators, as well as furnace dampers, for use in individual homes, a possible outgrowth of Pickels' modifications of the early Watts designs.

The Watts Regulator Company still sold the gravity-controlled regulators invented by Joseph E. Watts, but Pickels had capitalized on improved materials technology. New metallurgy made dependable and long-lasting metal springs available, and rubber processing had matured to the point where rubber gaskets had become reliable. As a result, several new regulator valve designs incorporated both springs and rubber gaskets. These later versions were much smaller than Watts' designs, which required lever arms and external weights. Because these regulators were small, they would fit into the limited space available for commercial household plumbing and heating. Thus, Robert Pickels had laid the groundwork for the next direction of the Watts Regulator Company.



The cutaway drawing of the regulators, designed and created by Robert F. Pickels for the catalogs, also contributed to the early growth of the company. In praise of these regulators, Pickels adopted the slogan, "Recommended by all for simplicity, accuracy, sensitiveness, economy and durability."

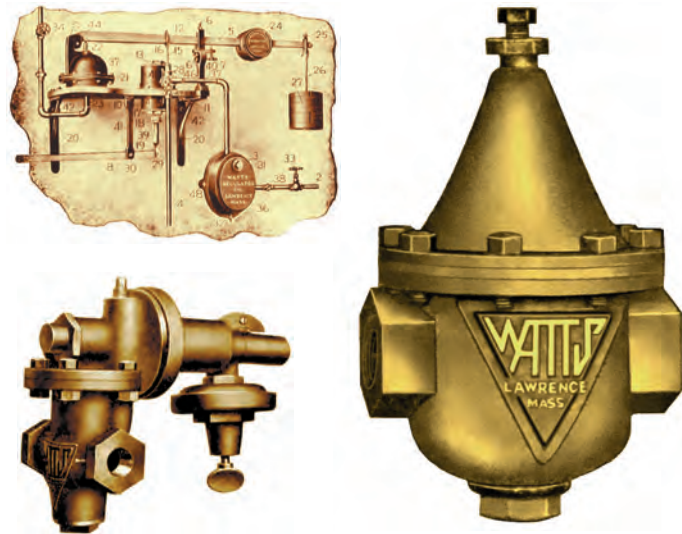

Watts' leading specializations at the turn of the century were Joseph E. Watts' own steam and water pressure regulators and an unpatented line of steam boiler damper regulators.



CHAPTER TWO A FAMILY BUSINESS, A NATIONAL FOOTING: 1918-1945

Robert F. Pickels had transformed Watts Regulator Company from Joseph E. Watts' small, localized enterprise into an established company with an identity distinct from its owners and a sales base that had begun to expand beyond the narrow horizons of the Merrimack Valley. After nearly a quarter century at the helm, Pickels put Watts up for sale.

In the fall of 1918, a trio of Lawrence men each invested \$25,000 to purchase Watts Regulator: Burchard Everett Horne; his uncle Herbert W. Horne; and a mutual friend, Norman Anderson. Within a year, Burchard Horne had acquired Anderson's share of the business and soon purchased his uncle's portion as well. The transfer marked a new era for Watts Regulator as a family-owned-and-operated business.

The Horne family had a long association with the Lawrence area's textile industry. In 1861, young George W. Horne, Burchard's grandfather, moved to Lawrence from Lowell, where he and his brother had been contractors, builders and roofers. He acquired the regional franchise for Bee-Hive Brand Felt Roofing and formed the George W. Horne Roofing Company, a venerable concern that roofed both large buildings and private residences since the

mid-19th century and still operates locally. Among Horne Roofing's largest customers were commercial and industrial concerns — in particular, the textile mills in Lawrence and other buildings as far north as Dover, New Hampshire. Both Burchard and his uncle, Herbert W. Horne, were active in the family roofing business, though Burchard, more commonly known as B.E., came to control it.

Despite a postwar recession in textiles, America's overall industrial output was expanding in the years immediately after World War I. But the chief industries of Lawrence and the rest of the Merrimack Valley were beginning a slow and prolonged decline. The need for uniforms during the war had created a surge in demand that obscured a basic change in the U.S. textile industry. Shortly after the Civil War, many manufacturers of textiles — including those in the Merrimack Valley — had turned from water power to steam to gain greater efficiency. That change in energy source stripped the Merrimack River textile mills of their geographic advantage, for steam power was independent of a river location; it could be delivered efficiently wherever fuel was available. New textile producers began to set up shop in the South, principally in the Carolinas and Georgia, where labor was cheaper, taxes were lower and regulation was minimal.

Opposite: Burchard Everett Horne breaks ground for the new Watts Regulator plant in 1937.

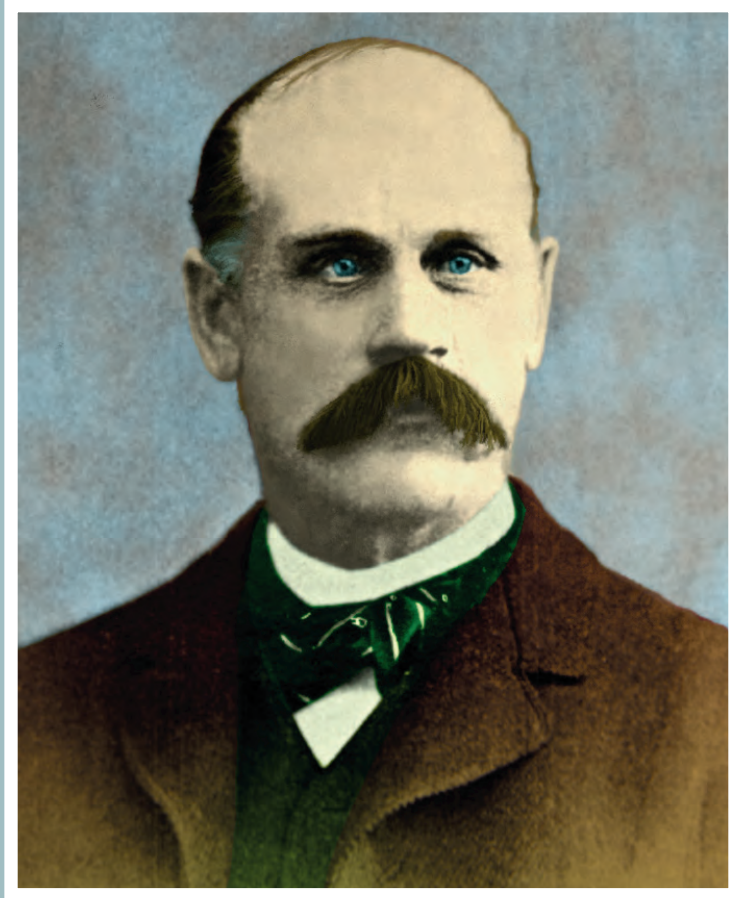

In 1861, **George W. Horne**, Burchard's grandfather, moved to Lawrence and established a successful roofing company. His two sons, George H. and Herbert W., were active in the family business, which roofed not only commercial businesses, but also private residences.

H. W. HORNE J. NORMAN ANDERSON B. E. HORNE

WATTS REGULATOR CO.

Established 1874

Manufacturers of

POWER PLANT AND HEATING UTILITIES

Including

Air Valves	Boiler Stop and Check Valves
Automatic Damper Regulators	Central By-Pass Valves
Automatic Engine Stops	Electric Feed Water Regulators
Automatic Rheostat Controllers	Electric Tank Regulators
Back Pressure Valves	Fan Engine Regulators
Balanced Float Valves	Gravity Tank Regulators
Balanced Lever Valves	Pump Regulating Valves
Balanced Throttle Valves	Reducing Pressure Valves
Boiler Feed Water Regulators	Steam Traps
Boiler Stop Valves	Vacuum Pump Governors
Water Line Regulators	

INTRODUCTORY

For more than forty-four years, we have been working with the constant aim of producing the best line of steam specialties to be found anywhere.

Our steadily increasing trade in all parts of the country leads us to believe that if we have not succeeded literally, we have at least done so comparatively. If the Watts Regulators are not the best, there are certainly none better.

Our standard types of regulators, the tried and proven kind, remain the same and hold their place as leaders. We are not so bound down with our standards, however, as to be either unable or unwilling to furnish special apparatus when necessary to meet changing conditions.

These facts, together with our increased facilities of manufacture, keep our products in the lead.

We wish to express our appreciation of the confidence of the engineering profession, as shown by increasing patronage, and our firm purpose is to merit this confidence.

Our valves have long been recognized as the true standard of excellence for quality, efficiency and economy.

Their practical design coupled with high grade material specially adapts them for high pressure superheated steam service, and the workmanship is of that high order which characterizes all Watts Products.

The broad scope of the Watts line of valves provides a type and size for every service requirement.

"Watts equipped" is synonymous for Safety, Service and Economy.

WATTS REGULATOR CO.

PLEASE TAKE NOTICE . . .

All valve bodies screwed ends up to and including 2" are made of Composition Bronze, over 2" cast iron bodies flanged ends with our Special Composition Bronze fittings.

Valve bodies can be made of steel with monel metal parts. Prices furnished on application.

If you do not know exactly what will suit your purpose, write us fully the conditions stating what you wish to accomplish and the matter will receive our prompt attention.

We claim to be able to regulate and control any pressure or temperature of any fluid for any purpose and under any conditions.

All inquiries will receive our special attention and orders will be delivered promptly.

Where advice is not given, we reserve the right to ship regular types, using our best judgment at buyers' risk.

We carry a large stock of these goods on hand at all times.

Give full shipping instructions.

All our goods have a positive guarantee behind them that is lived up to. Specify Watts and insist on having the genuine.

With textile mills moving South, the Watts Regulator Company switched its emphasis — as evidenced in the opening page of Catalog 19 — from valves and regulators with textile industry applications to applications for plumbing and heating uses.

Catalog 19 underscored the Watts Regulator Company's prescient view of changing conditions within its industry. Watts featured flexibility, demonstrating its willingness "to regulate and control any temperature or pressure of any fluid for any purpose and under any conditions."

At the same time that the textile industry switched from water to steam power, the introduction of looms equipped with automatic bobbin changers (beginning in 1894) brought about a dramatic increase in weaving productivity. By the early 1920s, New England millowners could see that, on a national level, the productivity of the textile industry exceeded the demand for cloth. The writing was on the wall: Higher labor costs and taxes in the North would eventually drive New England textiles out of the region. The future of the industry lay southward, and the gradual exodus of the Merrimack River mills began — a process that was to take more than three decades.

The shrinking industrial base in and near Lawrence had direct consequences for

Watts Regulator. The company had been launched to service local mills and other manufacturers, but under Robert F. Pickels, Watts had diversified into general heating, steam boiler and even a few home plumbing applications. The Horne family owners lost no time in capitalizing on this shift. Their 1919 catalog referred at points to textile industry applications of Watts valves and regulators, but the main pitch was clearly directed at steam-power plant engineers.

Catalog 19 of Watts Regulator Co. described Watts as "Manufacturers of Power Plant and Heating Utilities." Although the new proprietors carefully stressed to their clientele the continuity of the company, they also emphasized new applications outside the mills. "For

more than forty-four years, we have been working with the constant aim of producing the best line of steam specialties to be found anywhere. Our standard types of regulators, the tried and proven kind, remain the same and hold their place as leaders. We are not so bound down with our standards, however, as to be either unable or unwilling to furnish special apparatus when necessary to meet changing conditions."

"We wish to express our appreciation," the new owners continued, for "the confidence of the engineering profession, as shown by increasing patronage, and our firm purpose is to merit this confidence."





The George W. Horne Roofing Company, still operating locally, was the Horne's first family enterprise and a harbinger of the success that was to continue with the Watts Regulator Company.

Flexibility was the key word. "If you do not know exactly what will suit your purpose, write us fully the conditions stating what you wish to accomplish and the matter will receive our prompt attention. We claim to be able to regulate and control any temperature or pressure of any fluid for any purpose and under any conditions."

This claim may have seemed mildly boastful, but it was a prescient view of the capabilities that Watts Regulator would develop as the century progressed. If there was an exaggeration in the initial catalog from the Burchard Horne era of Watts Regulator, it was that "we carry a large stock of these goods on hand at all times." B.E. Horne was a cautious businessman, and he did not like to stockpile

inventory on speculation, preferring instead to wait for orders, a predilection that his managers recall with a mixture of humor and frustration as they awaited delivery of the raw materials to make the finished goods for which "prompt delivery" was also promised.

By the mid-1920s, the public face of Watts reflected other changes. Not only did the owners' names no longer appear in the catalog — for B.E. Horne alone controlled the company — but water pressure-reducing valves had moreover assumed new prominence in the product line, as did oil control valves. On the cover of Catalog 20 was the proud announcement that Watts was a member of the National Association of Steam Specialty Manufacturers. This membership presaged another Watts' propensity: to be a player when the standards were established.

With business in the Merrimack Valley beginning to slack off, B.E. Horne was looking for fresh markets. While revamping the line of goods offered by Watts Regulator, he also began to address the task of marketing Watts products to new customers, first by enlisting Walworth Manufacturing Company as "Exclusive Sales Agents for United States." Walworth maintained central offices in Boston and branches in Philadelphia; Seattle; New York; Chicago; and Portland, Oregon. To manufacture valves and regulators for this national, if limited, market, Watts Regulator employed a dozen men to machine parts and also assemble the finished pieces.

WATTS REGULATOR COMPANY

250-252 Lowell St., Lawrence, Mass.

Member of
National Association of Steam Specialty Manufacturers

Becoming a member of the National Association of Steam Specialty Manufacturers also demonstrated the company's ability to work with the future. The membership provided Watts with the opportunity to be a player when the standards were established.

WATTS REGULATOR
C O M P A N Y
LAWRENCE, MASSACHUSETTS



WALWORTH MFG. CO. :: SELLING AGENTS

General Offices
BOSTON, U. S. A.

Eastern Division
BOSTON

Western Division
KEWANEE, ILL.

Branch Offices

BOSTON, MASS.
142 High Street

NEW YORK
19-22 Cliff Street

CHICAGO

220-222 No. Desplaines Street
PHILADELPHIA, PA.

SEATTLE, WASH.
414 First Avenue South

241-247 Arch Street

PORTLAND, ORE.
Twelfth and Everett Street

With business decreasing in the valley, B.E. Horne enlisted the services of Walworth Mfg. Co. for distributing to new customers on a national level.

Opposite: The adaptation of the automatic bobbin changer to the looms of the 1920s created a new dimension in the weaving and textile industry.



After switching to John G. Kelly, Inc. for national distribution, Watts Regulator Company landed a contract with Consolidated Gas of New York.



The Watts Type 26 valve was utilized by every gas-powered refrigerator made by Consolidated Gas.



Watts Regulator Company's product line in the 1930s reflected the company's expansion of products, but Watts still emphasized the temperature and pressure (T&P) valves, its key to "opening doors" with new customers.

How well the relationship between Watts and Walworth fared is subject to speculation, but by the late 1920s, Watts had switched to John G. Kelly, Inc. of New York City for exclusive national distribution. Kelly's coup was to land Watts Regulator a contract with Consolidated Gas of New York. "In those days, they made a gas refrigerator," recalled B.E. Horne's son, George B. Horne, speaking of the era of mechanical refrigerators powered by gas. "It was quite lucrative for us because they ordered up to 50,000 of our Type 26 valves. One went into every refrigerator." The Type 26 valve, as shown in the catalogs of the period, was a relatively simple pressure reducing valve "for water and air primarily. Especially recommended for its sensitiveness and reliability on low pressures," the copy from Catalog #30 (1930) read. "But as progress would have it," George Horne recalled, "they redesigned the refrigerator and didn't need the regulator. We were in and then out - a product boom for a few years when they needed this pressure regulator for the gas icebox to function."

But B.E. Horne — an avid outdoorsman and a fierce competitor, having held the national double-blade canoe championship for three years in his youth (1908-1910) — was not the sort of man to let one setback topple the business. Although powerplant applications had been Watts Regulator's bread-and-butter business when he first acquired the company, B.E. Horne moved the company decisively into residential, commercial and industrial heating and plumbing products. He and his chief engineer,

Wendell Dillon, made both small improvements in designs and developed a few completely new ones. The key breakthrough, however, came in the late 1920s with the development of the combination temperature and pressure relief valve under patent protection.

"The temperature and pressure relief valve, or T&P valve, as it came to be called, was the key that opened the door for us," George Horne recalled. "My father got to know Chetwood Smith, who had the patent on a combination temperature and pressure relief valve. Smith had no manufacturing facilities, so he came to my father, whom he knew as a small manufacturer, and said, 'Look, I've got the patent, you develop it.' We had a fair complement of machinery at Watts," George Horne remembered. "That's always been one of our fortes beginning with my father. We always went for the very best high-production machinery you could buy. It was worth it because it paid for itself. We were always well ahead of our competition on machine tools. If you could pay for a machine in two years, then it was worth buying!"

The T&P valve was revolutionary for the proper protection of hot-water supply tank systems. Domestic hot-water supply tanks and heaters had long been recognized as potentially dangerous, for the buildup of excess heat inside a tank could lead to explosion. The initial solution to this problem was to equip domestic hot-water tanks with pressure relief valves. When the internal pressure built up beyond a certain limit, the valve opened to drain the heat-expanded water.

UNITED STATES PATENT OFFICE

1,941,023

COMBINATION RELIEF VALVE

Chetwood Smith Worcester, Mass.

Application May 11, 1931. Serial No. 536,395

Dec. 26, 1933.

C. SMITH

1,941,023

COMBINATION RELIEF VALVE

Filed May 11, 1931

2 Sheets-Sheet 1

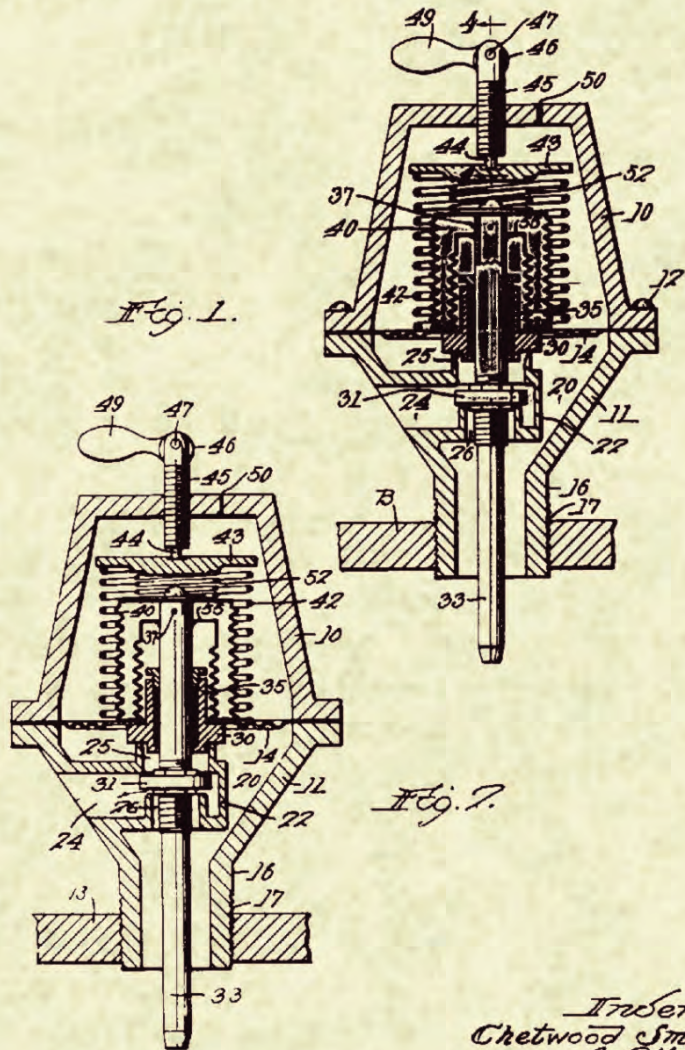

Inventor
Chetwood Smith
By Attorneys
Sullivan, Hayes & Hawley

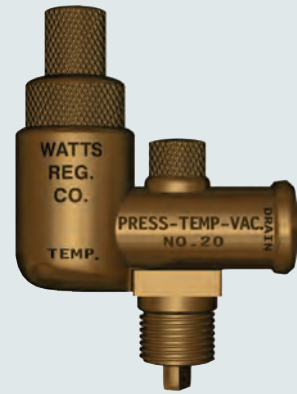

A vacuum protection version of the new T&P valve kept the water tank from collapsing should a vacuum be created on the main supply line.

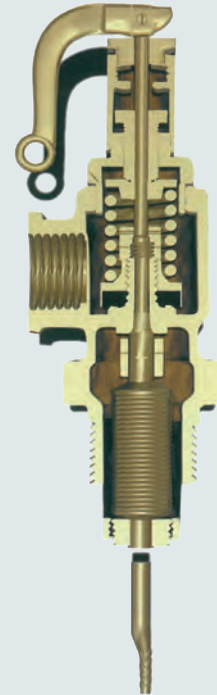

The T&P valve used a thermostatic bellows that opened the valve to drain the hottest water from the top of the tank to reduce the temperature.

Chetwood Smith's patent on a combination T&P relief valve proved to be a key sales breakthrough for Watts Regulator in the ensuing years of the '30s and '40s.

But hot-water tanks continued to explode. The culprit, it turned out, was not so much pressure as it was excessive temperature. Without temperature relief, a typical domestic water heater can heat water to levels far above 212 degrees F (100 degrees C). Furthermore, water overheats faster than a pressure-relief valve can release the overheated water. Moreover, water boils at higher temperatures under pressure (see chart). Water heated above its atmospheric boiling point flashes to steam on contact with the atmosphere and can release explosive levels of thermal energy, sometimes causing serious explosions that have destroyed property and killed people in the past. Superheated, pressurized water could exit as steam from shower heads or faucets or damage water meters by backing into the cold water line. The elevated temperatures of water, even above 160 degrees F, shorten the life expectancy of storage water heaters through increased corrosion and the weakening of metal from heat stress. Chetwood Smith's solution was simple: Add a plug of material that would melt at 210 degrees F.

Table 3 Energy Release

Pressure Lbs. Per Sq inch	Temperature At Boiling	Ft. Lbs Energy Liberated
0	212.0 °F	-
10	239.5 °F	479,800
30	274.0 °F	1,305,000
50	297.7 °F	2,021,900
70	316.0 °F	2,642,000
90	331.2 °F	3,138,400

The original T&P valve was designed to alleviate the dangers of overheated water (above 212 degrees F) in all domestic hot-water supply systems.

The new T&P valve had a drawback, however, which was that once the plug melted, water drained out, requiring a service call to replace the plug. Still, it provided a level of safety for hot-water tanks that had never existed before. Watts went into immediate production of the Smith version of the T&P valve, but it also developed a more sophisticated T&P valve that would reseal automatically. The new valve used a thermostatic bellows that would open the valve at approximately 210 degrees F to drain enough of the hottest water from the top of the tank to reduce the temperature by at least 10 degrees F. Once the temperature went down, the valve closed again and the system could resume normal operation.

The T&P valve line became key to Watts Regulator's progress. "We had the exclusive right of that patent," George Horne recalled. "Later, we licensed other manufacturers so they could make the valve but they could not undersell us. They had to pay a royalty. Everybody's price was the same. Getting the sale was a matter of delivery and design preference."

Beginning in 1936, "getting the sale" became George Horne's responsibility. His father had grown impatient with the performance of John G. Kelly, Inc. Kelly had offices in Boston, New York, Chicago and Detroit, but its self-proclaimed "nationwide" sales coverage was scant. "My father was anxious to set me up as the marketing man and sales manager to go directly to the sales representatives and cancel out John G. Kelly," George Horne recalled. "We boiled Kelly's territory down to New York State, Connecticut, Vermont, western Massachusetts, and northern New Jersey. Finally, we trimmed them back to New York State, New York

City, and northern New Jersey. Funny thing was, that as markets got more concentrated, Kelly actually got more business out of a smaller territory."

George Horne had been a small boy when his father took over the reins of Watts Regulator in 1918, but as he grew up, he had worked one month during the summers at Watts and another month in the family roofing business, George W. Horne Roofing. At Watts, George Horne helped run the lathes to machine parts, and he tested and assembled valves as well — "doing a little bit of everything." The summer job was part of B.E. Horne's plan for his son to understand the business from the ground up. When George Horne left college, he immediately became the head of marketing for Watts. The only offspring of Burchard, George's entry into the firm made Watts a family business.

"It was Dad's idea for me to take over the national sales management" George said. "We started to grow by creating territories that were not previously covered. That's how we got our sudden growth." In short order, George Horne was on the road, going from city to city, asking plumbing suppliers from whom they bought products and tracking down the best salesmen in a region. Then, he sold the salesmen on Watts.

The product line was primarily plumbing and heating products, a result of B.E. Horne's move into that market during the 1920s. "There were hot-water heating dual controls and feed-water regulators, and relief valves for boilers," George Horne said. "But our leadership in the promotion of the T&P valves was the key, because it opened doors for other, newer products."

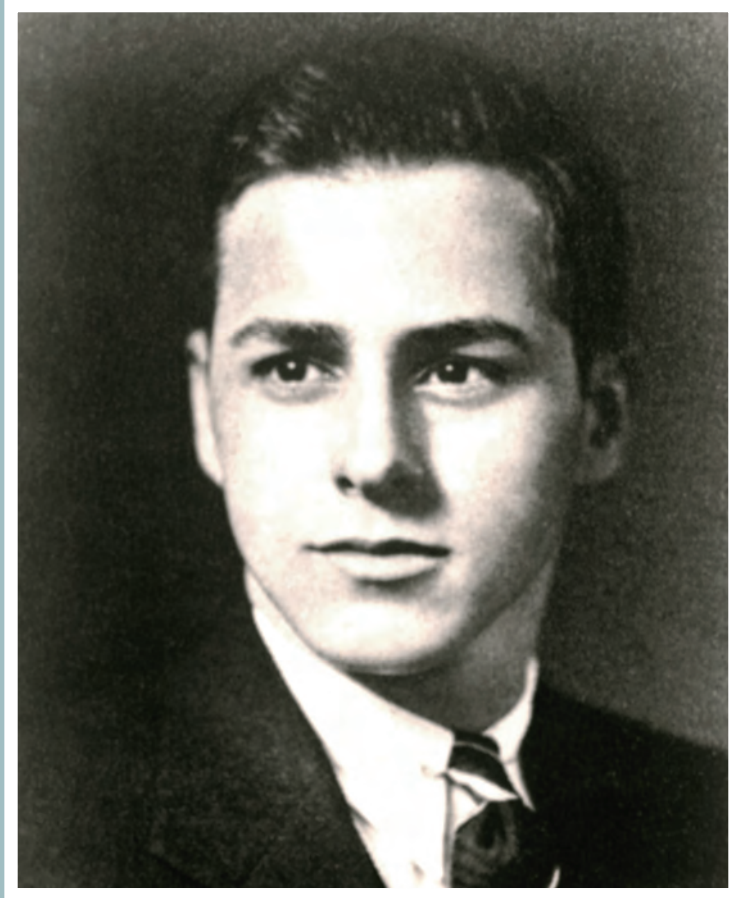

While growing up, **George Horne** worked one month a summer at Watts and another month at George W. Horne Roofing. In 1936, B.E. assigned George the tasks of marketing and sales to coordinate directly with the sales representatives across the country.

The Hornes knew their T&P valves could be large sellers because they solved some significant safety problems with hot-water supply systems. But the world had to know the products existed, and the plumbing industry had to be educated to understand the need for T&P valves. Since Watts was selling through plumbing and heating wholesale distributors, rather than directly to consumers, the company chose to put its case to the safety experts — those who wrote both national and local plumbing codes and standards.

In 1935, the American Gas Association (AGA) in effect rewarded Watts' efforts by sponsoring an American Standard 221-22 for T&P valves. But this standard was not immediately embraced at the local level. George Horne set to work making the case for water heater safety.

George Horne explained, "The object was to get more codes and ordinances throughout the country. We put on some explosion demonstrations. We would mount a tank in a field and put it inside the shell of a house and blow it up by overheating it, proving the need

for temperature relief to the plumbing inspectors who were invited to witness this phenomenon. They previously felt that pressure relief would stop the danger of explosion. Every plumber in the country thought that. But relieving excess temperature above a certain point was the real protector."

The public demonstrations were convincing. The tank to be overheated was fitted with a pressure gauge and a pressure relief valve. The pressure was visible through binoculars — 75 pounds per square inch, a normal operating pressure.

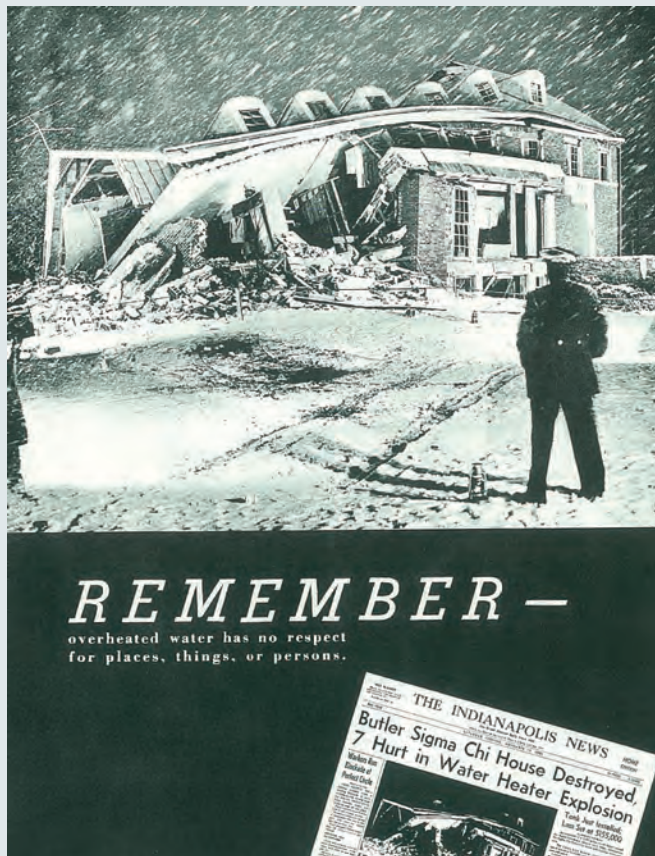

George Horne set about making a case for safety in the late 1930s. These efforts would help to establish a standard utilized nationwide. The educational campaign included advertisements and literature that graphically depicted the dangers of overheated water as well as a 16 mm film created by George entitled "Explosion Danger Lurks!"



George Horne also constructed dramatic presentations of mounting pressure and its consequent explosions, displaying the necessity for T&P valves.

**B. HOFFMANN
MANUFACTURING COMPANY**
INCORPORATED
181-1825 W. St. Paul Avenue
MILWAUKEE, WISCONSIN

● Relief Valves
● Pressure Regulators
● Low Water Cut-offs
● Boiler Water Feeders
● Hot Water Heating Systems
● Hot Water Heating Regulators

FORCED HEAT DEMANDS WATTS PROTECTION

FORCED HEAT DEMANDS WATTS Protection

THE MOST COMPLETE LINE OF ITS KIND IN THE WORLD . . .

CATALOG No. 37

WATTS REGULATOR CO.
Lawrence, Mass.

Page 1

WATTS RELIEF VALVES
Specially Designed to Protect Domestic Range Boilers, Storage Tanks, etc., Against Damage From Excessive Pressure, Temperature or Vacuum.

Range boilers and storage tanks are designed and built to work safely at pressures specified and marked on the tank by the manufacturer.

Should the working pressure occasionally, moderately, exceed the manufacturer's rating, the tank will not necessarily become cracked in the joints of valves, nor will constant working pressure, moderately in excess of the rated working pressure, cause immediate failure but the tank may become so strained that it will fail long before its normal life.

Failure to protect the tank against excessive pressure, caused by water expansion when heated, may result in a burst tank. When a pressure regulator is installed in the supply to the tank for the purpose of reducing the pressure in the house service pipes, or a check valve is installed to prevent the water from flowing in excess of the tank, when expanded from heating, cannot leak up into the street main. Then again, the supply valve may be accidentally closed or some other stoppage in the cold water supply may not allow the water to back up into the main as it expands.

When such conditions exist, the expansion of the water, when heated in the tank, builds up a pressure sufficient to rupture the tank, causing costly replacement of equipment and possible expensive water damage to the building and furniture.

While excess pressure may burst the tank and cause water damage, the heated water from the excessive temperature, temperatures above 212° in the tank are dangerous. Should a rupture occur in a tank in which the water is heated to above 212°, a part of the superheated water will flash into steam and cause an explosion which may crack the building and cause personal injury. The higher the temperature in excess of 212°, the greater will be the damage.

Tanks heated by combustion gases, heaters, such as stoves or heaters in the kitchen, should be protected by a reducing type fully automatic relief valve. With these heaters it is impossible to control the amount of water heated, and an overflow means that a relief valve which will drain off some of the heated water, will do nothing to enter the tank and cool it. For stoves without a danger regulator, or gas heaters without thermostats may be forgotten and overheat the tank, causing explosion, property damage and personal injury. For such installations, in which overheating may be a chronic condition, fully automatic protection is advisable.

The fully automatic valve is recommended on such installations in preference to the fusible plug type because of automatic reset, whereas it is necessary after relief to reset the plug of the fusible plug type. This necessitates shutting off the water and the trouble of resetting the plug. Closing, preferably requires frequent repairs, which mean expense.

For emergency protection of heaters, normally under thermostat control, a fusible plug type of valve can be safely used. Such protection is only needed in case the thermostat fails.

Occasionally accidental conditions develop which create a partial vacuum in the tank. A broken water main, the pump drawing hard on the water supply, may reduce the pressure, or even cause a vacuum, which opens the water out of the supply pipes, emptying the partial vacuum. The vacuum may be so excess that which the tank will hold and it will collapse.

For Watts No. 112 low vacuum protection.

Series 20 has vacuum combined with pressure and temperature relief.

SAFETY IS A MORAL OBLIGATION OF EVERY HOT WATER HEATER SALE

for . . .
COMPLETE PROTECTION WITHIN THE HOME . . .
INSTALL WATTS VALVES

No. 108 Fully automatic pressure and low pressure relief, before and means. The best of the kind.

No. 109 Pressure temperature and vacuum relief. Exact features automatic. Fully automatic.

No. 112 Low vacuum protection.

No. 110 Pressure and temperature relief.

No. 111 Pressure and temperature relief.

No. 113 Pressure and temperature relief.

Page 11

HOT WATER HEATING REGULATOR

The DEMAND for SYSTEMS is GROWING

SPECIAL FEATURES OF WATTS SYSTEMS

The evolution of the hot water heating system, from its early principles involving the open expansion tank and its location of performance and temperature range to the present highly efficient system, has followed definite lines of scientific research.

With the original open expansion tank, the pressure was limited by the height of water in the system. This naturally limited the maximum temperature that could be safely carried without driving the water out of the tank due to formation of steam. Large radiators were required, the speed of circulation was limited and large pipe sizes were needed. Other radiators of smaller parts of the system were damaged and did not heat properly.

Research indicated that a system under pressure contained better volume relative heated radiators, higher temperatures could be safely carried and smaller radiators were a considerable time saver. From the closed system was accepted as the new standard of installation.

WATTS AMONG FIRST IN FIELD

When the closed heating regulator was accepted the first in the field. Progress in refinement of construction has followed a steady upward path and those with the most advanced have been made. Stepping ahead of all other manufacturers, Watts has developed the closed system with a safety test lever, a feature not required by the A. S. I. or U. S. standard relief valves for hot water heating.

WATTS DEVELOPED LESS COSTLY UNITS

Complete systems required the application of pressure regulators, and these Watts has provided. Built in the low pressure units, Watts has developed the closed system without need of valves, and safety test lever, and safety test lever, and safety test lever.

Checkable control of the closed pressure system is an important feature. Watts has provided the means for the safety test lever, and safety test lever, and safety test lever.

Many contractors prefer to use a tank valve and relief valve as an alternative with Watts. The practical installation with the system device for each type of installation is provided to ensure accuracy in the use of these two methods of installation.

GENERAL INFORMATION

A basement expansion tank should be used in all closed systems which will not be used in the main or in the water supply. The tank is used to absorb the expansion of water in the system, and to prevent the water from being heated and pressure in the system to rise to a point which will cause the tank to burst.

Without the tank, water is frequently discharged from the system through the relief valve and the tank is not used for the tank valve to regulate the water level. The proper installation of the tank is essential to the proper operation of the tank and which will regulate the water level in the tank by increasing the water level and the water level in the tank.

Watts and manufacturers must be accurate in the installation of the system in the basement. Watts has provided the means for the safety test lever, and safety test lever, and safety test lever.

Years before any national safety standards were established, George Horne's educational program emphasized the importance of T&P protection for hot-water heaters.

“But as the pressure relief valve discharged faithfully at its set pressure of 75 pounds, the temperature continued to rise above 210 degrees and finally when the tank was weakened by heat, there would be a small rupture and — BOOM! — it exploded just like TNT,” George Horne recalled. “That’s the power of superheated water.”

One of the more dramatic surviving artifacts of this educational campaign to get T&P valves specified in safety codes is a film created by George Horne in the 1930s called “Explosion Danger Lurks!” The old 16mm film still circulates in a videotape edition.

As George Horne set about widening geographical markets for Watts and as the T&P valve gave the company a better share of other product markets, Watts Regulator began to increase sales sig-

nificantly. “When I entered the business in 1935, Dad was doing just \$200,000 of business a year, with a margin of about 25 percent. Today that’s not even a good hour’s business, but it was a whole year then.” In 1936, sales went to \$300,000, then \$400,000 and so on. In 1939, George Horne convinced his father to sell the family roofing business, where he was spending half of each day, and to devote all his energies to Watts. “I told him, Dad, we’re doing so much business I need you here to make sure we can fill these orders.” The country may have been in the economic doldrums of the Great Depression, but business was improving at Watts Regulator.

George Horne’s educational program related to the T&P valves helped — city after city and then finally, nationally, safety standards began to specify T&P valves on hot-water heaters. Significantly

for Watts, many years before national safety standards went into effect, U.S. Army Engineers required T&P protection valves on all Army hot-water supply tank installations. When World War II broke out, new barracks went up all across the country, and Watts either supplied the T&P valves or received royalties from other companies that did. The war also boosted volume of the Watts regulating valves that were designed to control air pressure. The valves were essential to control the instrumentation in plants that produced synthetic rubber and high-octane airplane fuel — top priorities in the war effort. As George Horne recalled, “Watts suddenly had 200 people working in the plant around the clock in three shifts.”

The company had come a long way from the small shop of a dozen machinists producing steam regulators for the textile mills.



WATTS
Regulator Company

CHAPTER THREE GROWING WITH AMERICA: 1945-1959

Shortly after the war, the Watts patents on T&P valves expired, leading to what George Horne called “gutter competition.” The Watts T&P valve had bolstered the company’s reputation to the point that some suppliers were surprised to learn that Watts produced an entire line of leading design-valve specialty products. But once the patent protection vanished, the company found itself as simply another player in an increasingly crowded field. Profit margins on T&P valves dropped to low double digits.

George Horne’s response was to carry on as before the war: pushing the sales force to expand territories and cover each one thoroughly. Sales targets rose steadily, and new hands came on board to meet targets and increase the density of coverage. If margins were down, then the goal was to make up the difference in volume.

Watts also introduced new products. As the company geared up for a larger role in domestic plumbing, it introduced a revised T&P valve called the Series 40 Autotherm and a device that was to presage later developments, a hot-water-temperature mixing valve. The purpose of the mixing valve was straightforward: It automatically mixed cold water with hot water to deliver hot water at the tap at a relatively consistent temperature adjustable from 120 degrees F to 160 degrees F. Not intended as a safety-temperature

control valve, instead it extended the supply of hot water. Half a century later, in its continuing pursuit of excellence, Watts would still be refining the temperature-balancing valve.

The half-dozen years right after World War II was a period that might be described as the corporate equivalent of adolescence. In its youth, the company had begun as a machine shop and had branched out as a national manufacturer; now in adolescence, it began a growth spurt by expanding the product line and sales volume. With its ever-growing line of valves, Watts’ variety of parts on hand began to reach into the thousands. Orders were increasingly complicated. Old ways of doing business became tested to its limits.



Watts remained at the forefront in introducing new products and advanced designs.

Opposite: George Horne.



George Horne (page 28) emphasized an increase in sales force and product lines, while **B.E.** (above) concentrated mainly on managing the production and bookkeeping affairs of the company.

That strain was reflected in the two generations of Hornes who managed Watts Regulator. The push-pull between George and his father, B.E., occasionally grew heated. George's sales force was selling more valves than B.E.'s manufacturing employees could get out the door. Back orders began to pile up, and back orders hurt future sales.

When father and son argued, it was usually about the sticky question of how much inventory was adequate. In the absence of product forecasting, which was not to arrive until the 1960s, both views had their strong points. From B.E.'s perspective, inventory tied up capital. From George's point of view, lack of inventory meant untimely delivery, and late shipments translated into fewer or smaller orders. It was a battle neither won, but inventories were boosted, if not as much as George would have liked, certainly more than B.E. was comfortable with. Inventory was hardly an exact science at that point. As George Horne remembered it, "We'd knock down for a week every year and count the parts by hand."

The inventory situation epitomized what was happening to Watts. The company's difficulties, if they could be called that, stemmed from Watts Regulator maturing into a major national supplier of plumbing and heating valves. B.E. had already made concessions to modernity and success over and beyond his willingness to invest in the newest and most productive machinery. Although he still carried a notebook around with him that described the cost and pricing details of every Watts product, he had finally relented and hired a bookkeeper to share the numbers work. It is hard to imagine in today's business climate, but in 1950, the president of the company was still intimately familiar with every sale and expenditure. As often as not, the entry in the company's books was in B.E. Horne's own hand.



The end of World War II generated a nationwide demand for new housing, and Watts Regulator geared up for a larger role in domestic plumbing. Advertisements from this time promoted reduced water waste, financial savings and safety in public and residential buildings.

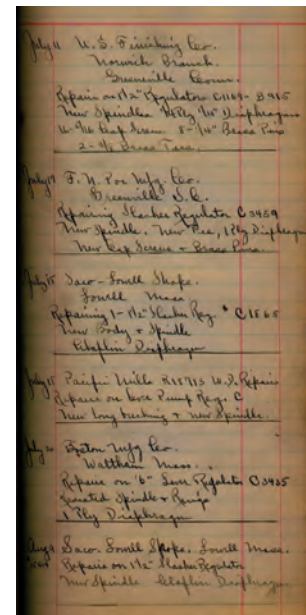

B.E. Horne kept a detailed record of the Watts accounts; most entries were painstakingly made out in his own hand. He remained intimately familiar with every sale and expenditure of the company until his death in 1951.



B.E., an avid outdoorsman and fisherman, died while on a fishing trip in Canada. The Watts Regulator Company passed directly to B.E.'s son, George.

But at the end of May in 1951, Watts Regulator underwent an unexpected and jarring change of management. A lifelong ardent sportsman, B.E. Horne set off on a three-week fishing trip with two companions (including the Midwestern sales representative for Watts) to a lodge near Sainte Anne du Lac in Quebec, Canada. On May 28, while fishing from a small boat, B.E. Horne collapsed — reportedly from a gallstone attack — and fell into the lake and drowned. His body was recovered the following day by the Royal Canadian Mounted Police. He was 64.

George Horne had been running the marketing arm of Watts Regulator for 17 years, but he suddenly faced taking charge of the entire company. Watts Regulator Company control passed intact to George, while B.E.'s widow, Mildred, inherited the personal bank accounts and properties. "My father was well enough off," said George, "but he wasn't a super rich man. Almost everything he made went back into the business — bricks and mortar. So when I inherited the company, it was a solid business but we had no real capital with which to expand."

Expansion was very much on George Horne's mind because Watts salesmen had created sufficient demand to strain the company's manufacturing capabilities to the breaking point. Moreover, he saw an expanding market ahead as Watts forged into new product lines and increased its market share in the lines it already produced. But prospective lenders did not necessarily share George Horne's sanguine forecast of the company's future. Watts Regulator was cash poor when George inherited it, and cash poor it was to remain for some time.

When B.E. Horne died, Watts Regulator Company sales totaled about \$3.5 million a year. But the market was growing, thanks in part to the postwar construction boom, and the company had a strong reputation for quality and no debt. Offers came in to purchase the company, but George Horne decided to tough out the tight years and build the company himself. George Horne was still the sales promotion executive, and he was determined to sell America on Watts.

Under a new generation of leadership, Watts Regulator began to change, and that change reflected George Horne's way of doing business. The personal touch expanded from marketing into the management of all facets of the company. Long a man to do business with a handshake and to trust longtime associates, George Horne surrounded himself with people he knew. George was determined to transform the company with the resources he knew and liked best — people.

B.E. Horne had been a financial wizard, looking at the bottom line and tightly controlling every variable that might trim profitability. His motto might have been "Invest and Save." George Horne was more inclined to action and growth — selling, seeking new opportunities, conceptualizing a sales strategy or a product line and then delegating to others the task of putting those plans into action. Yet, he was also a tinkerer, as employees of the era remember him — looking into the details of a new design, adjusting the phrasing in a brochure and double-checking the catalog copy before it went into print.

YOUR GREATEST

Potential Market...

1. Remodeling and replacement is the **WORK**
2. Your advertising and merchandising are the **TOOLS**
3. **WATTS** is... the **PRODUCT**

In every job where you install new bathroom fixtures, new kitchen equipment, or new water heating equipment, Watts protection and control specialties are potentially needed and important to complete the installation. Your reputation is our reputation. Guard it with products of merit and dependability.

YOUR JOBBER STOCKS WATTS PLUMBING
and HEATING SAFETY VALVES and CONTROLS

WATTS REGULATOR COMPANY

LARGEST AND MOST COMPLETE LINE OF ITS KIND IN THE WORLD

Service

THE EVENING TRIBUNE - LAWRENCE, MASS - TUESDAY, JUNE 28, 1948

Manufacturing Firm Keeps Pace With Modern Methods By Acquiring Plane

FAMOUS For SERVICE

Watts has always been famous for prompt shipments and meeting delivery requirements. During World War II when critical materials were in short supply and when civilian requirements had to come last according to priority, we nevertheless fulfilled our customers' needs on schedule when many others could not supply the requirements.

Even during the recent New England truck strike, we completed all orders before our vacation shut-down the first two weeks in July, by one means or another. For some shipments that had to be completed on schedule and which had to be shipped by truck, we put our executive aircraft into airlift freight service between Lawrence and Philadelphia as shown in the newspaper clipping.

This is in keeping with Watts tradition to fill orders promptly and on schedule, even through unforeseen limitations or difficulties exist.

This symbol proves This product worthy

WATTS REGULATOR COMPANY
LAWRENCE, MASSACHUSETTS

THE LARGEST Line Of Its Kind

George's more personal style of leadership was also reflected in the advertising of this period. Watts emphasized its reputation as a company devoted to safety, reliability and service.



A family atmosphere was cultivated by George Horne (seen here at the national sales meeting, front row, fifth from right) throughout Watts' national sales force, providing the company with a devoted following.



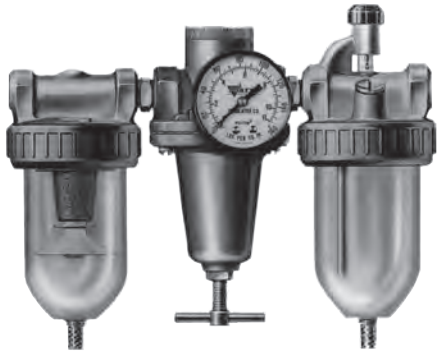

The Watts fluid power filters, regulators and lubricators controlled pressurized air, which drove many of the tools in the new U.S. plants that were beginning to modernize.

Admitting that financial record-keeping was not his forte, George Horne delegated the numbers work to a bookkeeping staff. And more than most company presidents, he was constantly in the field, visiting the sales representatives and finding out what was selling and why. “I suppose I was chief cook and bottle-washer, so I spent a lot of my time traveling,” he said.

He cultivated a family atmosphere in the sales force, bringing in representatives from around the country to Lawrence and later to Andover to educate them in new product lines and treat them to a good time. Often, they came to his home. The agents loved him almost unanimously. Commissions often ran high during this era of Watts history, sometimes reaching 15%. When George Horne traveled, the sales agents were delighted to see him. In return, he picked their brains for ways to expand. “At the sales meetings we’d ask the salespeople, ‘Is there a product that you could sell that we don’t make?’” he recalled. “They would tell us and sometimes we would go ahead and produce such a product because they said there was a market for it. We’d make it and try to improve on existing designs.”

The company’s hard-earned reputation for quality helped. Watts could improve

on a design — with a stronger casting, a longer-lasting valve seat, closer tolerances — and compete in the marketplace as the quality leader. “It was a struggle at times,” George Horne admitted, “but we pushed research as much as possible from earnings.”

As the 1950s wore on, Watts began to create increasing capital with which it could finance the expansion its president had seen as essential earlier in the decade. Watts had branched out, opening a fluid power division to make valves and control devices principally used on machine tools powered by air pressure. It was a natural way to capture a critical market segment as U.S. manufacturing plants began to modernize and expand. Air pressure drove many of the tools in the new plants, and Watts fluid power filters, regulators and lubricators controlled the pressurized air.

So, by the late 1950s, George Horne had generated enough capital to expand the manufacturing plant as well as the need to do so. The “new” plant in Lawrence for which B.E. Horne had broken ground in 1937 had grown crowded and in desperate need of updating. But in constructing a new facility, George Horne broke with company tradition. His new plant, completed in 1959, was not in Lawrence, but in Franklin, New Hampshire.

Opposite: In 1955, Watts purchased a Beechcraft Model DIBS airplane. Normally used as a passenger aircraft, George Horne (pictured here with sales agent Mike Mercury) traveled frequently, attending sales conferences and meeting with agents, who were more often than not personal friends as well.



WATTS *Regular*
SINCE 1875
LAWRENCE, MASS.



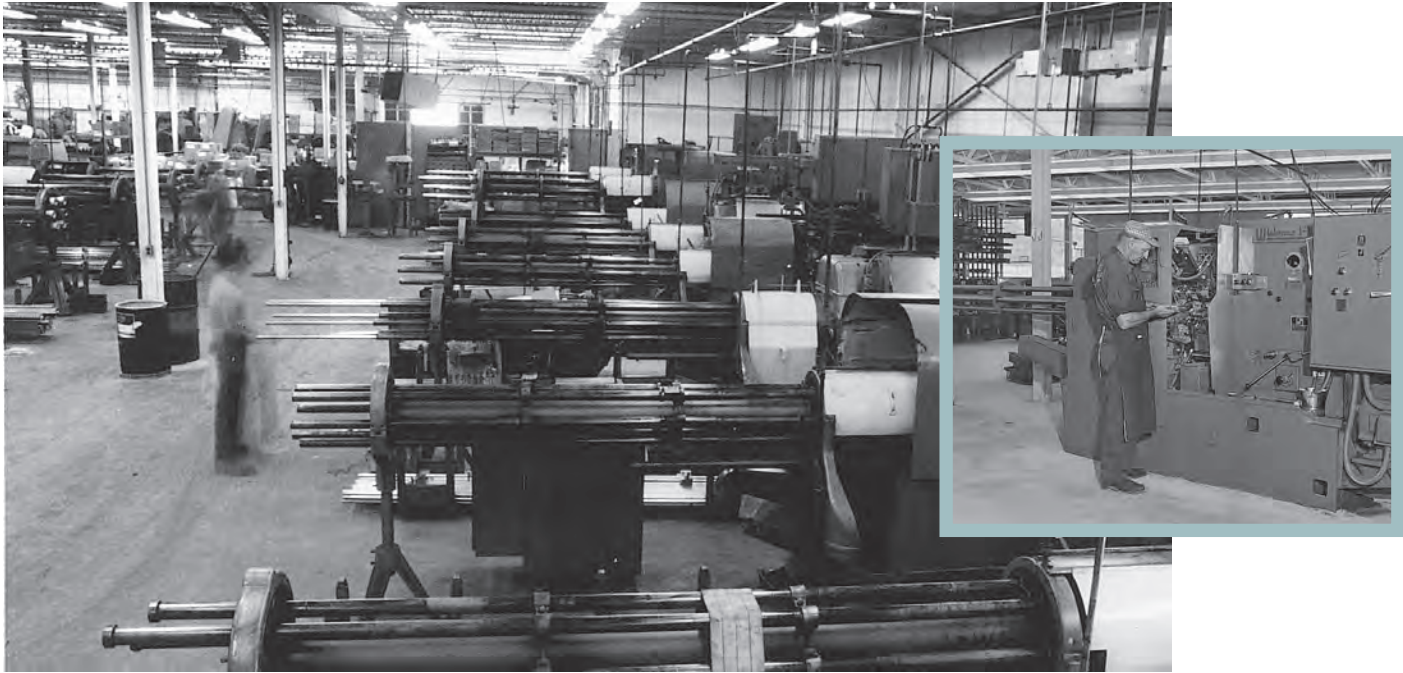

The Webster Valve plant, built in Franklin, New Hampshire, in 1959, occupied 73,000 square feet — plenty of room to accommodate a new generation of manufacturing equipment. Inset: A machine operator with an automatic screw machine.

In keeping with the Watts' belief, from B.E.'s time onward, in investing in the best tools available on the assumption that they would quickly pay for themselves, George had been bringing in a new generation of manufacturing equipment. He purchased automatic screw machines to make valve parts — machines that did not demand an operator's constant attention. But the union had won work-rule concessions of one man per machine, even though a single worker could easily tend three machines, setting them up and checking them every few minutes for necessary adjustments. But job security was a paramount concern for the union, and the members would not budge. Convinced that the union was not interested in progress, George Horne built his new plant farther up the Merrimack River;

established a separate company, Webster Valve; and transferred much of the Watts' equipment to it. The Lawrence manufacturing operation continued to operate until 1970, but the workforce shrank from around 300 to about 50.

The new plant in Franklin occupied 73,000 square feet — immense compared to the old Watts operation. Before it opened, George Horne held his sales meeting in the facility. Voices echoed across the floor. "A number of the agents asked me how I could possibly justify such a huge new plant," George Horne recalled. "I told them, 'You're going to fill it by selling more valves.'"

He had another ace up his sleeve besides the new manufacturing plant. In 1958, George Horne set in motion some

of the personnel changes that would reshape Watts Regulator and position it for a dynamic future. His first hire was Robert Chaffee, who had been working for a Rhode Island competitor, Taco, Inc., to assume the position of manager of sales. And in 1959, before manufacturing even began at the Webster Valve plant, George's son Timothy entered the business. Between them, Bob Chaffee and Tim Horne represented the beginnings of a professional management structure. As Watts added professional managers at all levels, it began to emerge from the old pattern as a local company run solely by local talent.

A new chapter began, with the emphasis on realizing Watts Regulator's dynamic promise.

Opposite: The new nonunionized workforce at Webster Valve, and important personnel changes initiated by George Horne in 1958, were responsible for a dramatic change in direction for Watts Regulator.



CHAPTER FOUR THE ADVENT OF PROFESS- IONALISM: 1959-1972

Although Bob Chaffee and Tim Horne were the agents of a revolution in business style at Watts Regulator, they built upon trends that were already in place. In 1960, Watts had hired its first professional manufacturing executive to oversee operations in the Webster Valve factory in New Hampshire and its first comptroller to oversee and analyze the finances of the corporation. As a believer in state-of-the-art machinery, George Horne had ordered the computerization of Watts' corporate record-keeping. An early generation IBM computer — a large, punch-card-operated machine — rolled through the doors. After nearly a decade of steady growth, Watts had laid the foundation for a new era of expansion and market domination. It was a heady time.

George Horne named Chaffee executive vice president in 1959 and in a sense, Chaffee became George Horne's alter ego. Where George Horne led with personal charm and warmth, Chaffee drove the troops by force of personality. He had a strong will, a secure faith in his own judg-

ment and a talent for goading subordinates into achieving more than they believed possible. Although George Horne had sometimes put long-term loyalties ahead of job performance, Chaffee had little tolerance for lackluster results. But like George Horne, he commanded respect and loyalty. Tim Horne recalled that Chaffee moved quickly and confidently into control at Watts. "When I started in 1959, he had just been elevated to executive vice president. He became the number-two executive within one year because he showed my father that he had a professional attitude about how to build a sales organization and how to attract good people." Within a year of his move to Watts, Chaffee brought along another half-dozen of his former lieutenants. One of Chaffee's most trusted assistants at Taco, Robert Tesar, took over as sales manager for Watts Regulator's Plumbing and Heating Division. Tim Horne remembered the transition as speaking volumes about Chaffee: "A strong man always hires a strong successor. Secure people always want to have strong people around them."

Opposite: Bob Chaffee.

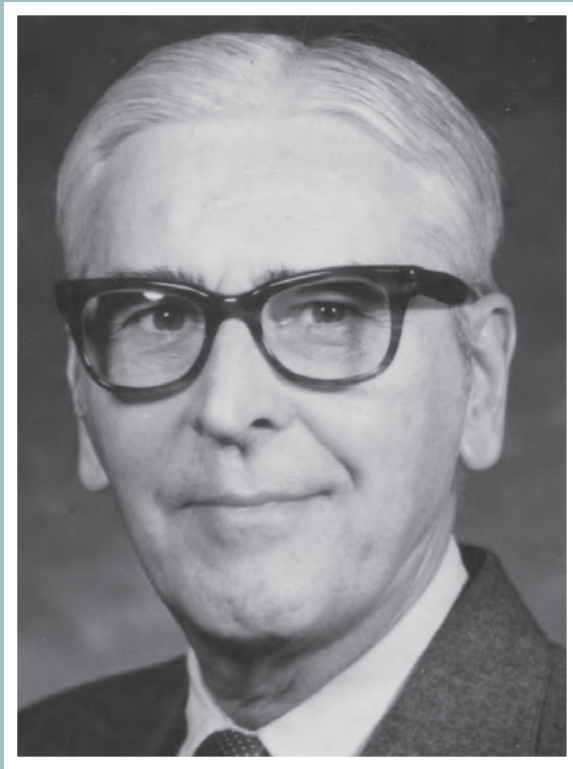

With George Horne at the helm, **Bob Chaffee** (page 40) as executive vice president, **Tim Horne** (right) as all-around executive troubleshooter and **Bob Tesar** (left) as head of sales, Watts had the executive leadership to remake the company into a modern mold.

With George Horne at the helm, Bob Chaffee as executive vice president, Tim Horne as all-around executive troubleshooter and Bob Tesar as head of sales, Watts had the executive leadership to mold the company into a modern corporation. “George Horne’s management style was informal but very direct and detailed,” recalled Tesar. “In fact, ‘detail’ is the key to the Horne management style. B.E. Horne was a pipesmoking, manufacturing person who could look at something and tell you the cost of it. And later George Horne was able to apply that same level of detail to his specialties of new products and sales. But until the 1960s, while the business had its complexities, it wasn’t as complicated as it would soon become.”

With the growing array of parts and products and new markets, Watts was outstripping the ability of any one person to track all the details. By assembling a professional management team, George Horne institutionalized the individual’s grasp of all segments of Watts. The model he set — of responsibility distributed among the members of a management team — created an approach to management that could spark growth.

The new management team began to get regular profit and loss statements from its professional comptroller — and began to use them as a management tool. “We read them, we understood what they meant, we understood cash

flow,” said Tim Horne. Being able to pinpoint the company’s financial status at any particular moment translated quickly into getting a similar handle on product flow. Tim Horne and Bob Chaffee began to develop Watts’ first preplanned product forecast as an alternative to the old system. Tim Horne shakes his head as he recalled, “At one time the system simply said, ‘Oh, we’re at reorder point.’ Of course, that was always too late. We would run out of products. We were operating on a purely reactionary basis, so we had to move to a planning process of forecasting.”

Demand was strong because Chaffee, with Tesar as his right-hand man, rebuilt the Watts sales force from the ground up. “Bob Chaffee replaced probably two-thirds of the sales representatives during his tenure,” recalled Tim Horne. “Some of the reps that we had, he said, were ‘fat and lazy.’ They were making an easy commission through built-in repeat business that did not encourage them to be more aggressive and broaden their sales base.” The sales agents loved George Horne, partly because he knew each one of them personally. Chaffee’s arrival was a sudden, cold shower for many of them. “The only problem with my father’s friendship with the agents was that he became subjective,” said Tim Horne. “Chaffee had a fresh approach. He didn’t care about the history. He was just looking for a better quality of sales representative.”



In keeping with the revolution in business style begun at Watts with the introduction of professional management, George Horne also believed in state-of-the-art technology. He ordered an early generation IBM computer that utilized large punch cards for corporate record-keeping.

Next page: With a carefully assembled professional management team, George Horne (in lower left-hand corner, seated with his sales representatives at a national sales meeting) set forth an approach to management that could spark growth. They put modern management tools to use, keeping careful track of inventory in order to meet the growing demands of the new sales force.







Kevin Sweeney, current executive vice president of Watts Regulator's Water Products Division, began his career at Watts as a young man servicing hot-water circulators in the New York market. The circulators were later dropped from the product line, but Kevin rose steadily upward in management.

One of Sweeney's strategies was to pursue the market for manufacturers of equipment that would use Watts valves. "The biggest and quickest impact on sales was to develop the OEMs," explained Sweeney. "We started a massive manufacturer's guide to Watts products when I was in New York and carried the same philosophy out to the Midwest. That enabled us to build an immediate base. It usually took longer to develop an OEM than a distributor, but once you had the account, maintenance was easier than with distributors." The Watts approach, guided by Chaffee, was to develop a "hit list" of potential OEM customers such as water heater manufacturers and boiler manufacturers. Regional sales offices reviewed the list at monthly sales meetings and targeted accounts. A direct mail program was launched through the guide to interest manufacturers to Watts products and collateral literature. When a manufacturer indicated interest, a salesman made the call.

At the same time, Watts also expanded into private labeling of valves for merchandisers who wanted to offer the products under their own names but did not want to tool up to produce the valves themselves. One of the most successful private-label arrangements was with Sears, Roebuck. Explained Tim Horne, "Sears started point-of-display blister packaging in their stores, so they

became one of our largest customer for temperature and pressure relief valves. We blisterpacked them and they put them on the hooks in their stores in their plumbing sections and in the Sears catalog. Those valves said 'Sears,' not 'Watts.'" The arrangement was doubly significant because the T&P valves were required by code for installation with domestic hot-water heaters — and Sears supplied one of every four electric hot-water heaters sold in the U.S.

Watts followed a private-label and OEM strategy as well for its fluid power division, which George Horne had launched in the mid-1950s and which, explained Tim Horne, "really blossomed in the 1960s. This was a line of products geared to the compressed air industry. Its most popular application was on air lines that operated machine tools. The machine tool industry, the automotive industry, and various OEMs represented the customer base. It was a completely separate market." During the early 1960s, American-heavy industries — especially the automotive industry — were gearing up new production lines almost every year, and the air pressure valve business was brisk. In 1962, Watts went international with fluid power, constructing a plant in Stroud, Gloucestershire, England, to sell into the U.K. and Europe.



Watts T&P valves, required by code for installation with domestic hot-water heaters, were sold under the Sears, Roebuck name in the plumbing section of Sears stores and in its catalogs.



In 1962, Watts went international, constructing a plant in Stroud, Gloucestershire, England, for selling in the U.K. and Europe.

At the same time, the company saw potential in other international ventures. Watts Canada, for example, had long been simply a sales agency for Watts Regulator's U.S.-made products. But in 1961, Watts purchased its first manufacturing plant in Canada and installed machine tool equipment. "We started manufacturing valves in Canada because Canada was proud and Canadians were truly angry about U.S. economic domination," explained Tim Horne. "So by having products that carried the Maple Leaf and the designation 'Made in Canada' we had

a vehicle to assume our fair share of the Canadian market." It was a strategy that paid off handsomely with strong market penetration. Although the Canadian population was about 10% of the U.S. population, Watts Canada had a greater market share per capita than Watts Regulator had in the U.S.

As Watts began to expand, so did the scope of Tim Horne's on-the-job training to eventually take over the company reins. In the early 1960s, he was named assistant to the president. And it was in that

capacity that he began to serve as Watts' chief union negotiator, just as his father George had taken over negotiations from his father before him. It was not a role that won any popularity contests for Tim Horne. "After I negotiated a contract with the union, I was no longer the popular son of the owner, my father, George," Tim Horne recalled ruefully. "I was their enemy and I was heckled in the plant when I walked through. It became a very adversarial relationship, ending years later with all the jobs in Lawrence being eliminated."

Opposite: Watts also established a manufacturing plant in Canada to join with its already established sales agency.





By the time **Tim Horne** was given the titles of vice president and assistant general manager in 1967, he had earned them. Sales had risen to \$17 million a year, and five years later when Bob Chaffee retired, Tim Horne again was deservedly promoted, this time to executive vice president.

In 1967, Tim Horne became vice president and assistant general manager. Having entered the business as the boss's son, by the time he won the titles eight years later, he had earned them. Sales, for example, had risen to more than \$17 million a year. He had been instrumental in developing Webster Valve in 1959, moving much of the manufacturing facilities in Lawrence up to the New Hampshire plant. The new facility greatly increased the space and workforce. When Bob Chaffee retired five years later, Tim Horne was named executive vice president. At that time, Watts Regulator was engaged in one of the definitive battles it waged to protect its markets and educate the public. Watts, under Chaffee's leadership, had sued the AGA in federal court under antitrust statutes for restraint of trade. Ironically, Chaffee was an active member of the AGA, who served on several committees of the trade association, and the suit involved a proposed code standard for hot-water heaters that was a revision of a code that Watts had helped to write three decades earlier.

The AGA had proposed a new code standard that could have led to the replacement of the temperature and pressure relief valve — a Watts flagship product — with an electrical control that would shut off a water heater when its water temperature rose above a certain level. Watts charged that there was a

conspiracy among several water heater manufacturers and a controls manufacturer to use the national, voluntary standards-making process to replace an independent mechanical control with an integral electrical one.

At the time, the national AGA code for water heaters called for a T&P valve to be installed at the same time the heater was installed. The valves were not supplied with the water heaters, but rather by the plumbers. Heater manufacturers argued that the new device — called an energy cutoff, or ECO — could be an integral part of the heater assembly and would allow them to guarantee the safety of their equipment. Watts argued otherwise and eventually enlisted many plumbing inspectors and some water heater manufacturers on its side to back a “belt and suspenders” approach — using the ECO as part of the water heater assembly but also requiring a T&P valve to be installed.

During the suit, Watts received a great deal of favorable publicity in the plumbing and heating industry for its educational programs on water heater safety. But by taking on an industry goliath and winning, Watts had established itself as a force to be reckoned with. It was not the last time the company would go to court to make its case for safety and for fair treatment.

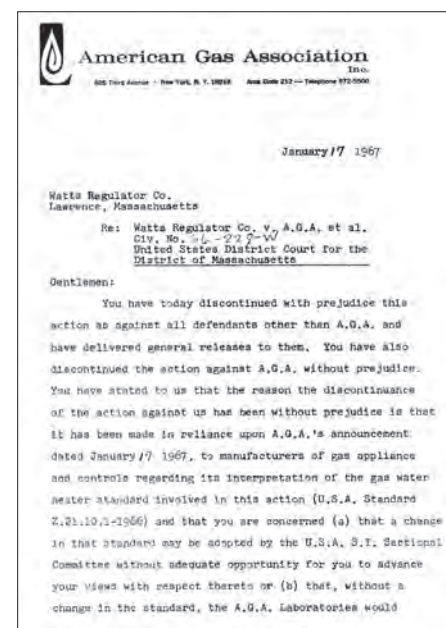

Watts established itself as a forerunner of modern safety codes and requirements by promoting educational programs. These programs sprang from an antitrust suit Watts brought against the American Gas Association from 1965-1967 for restraint of trade.

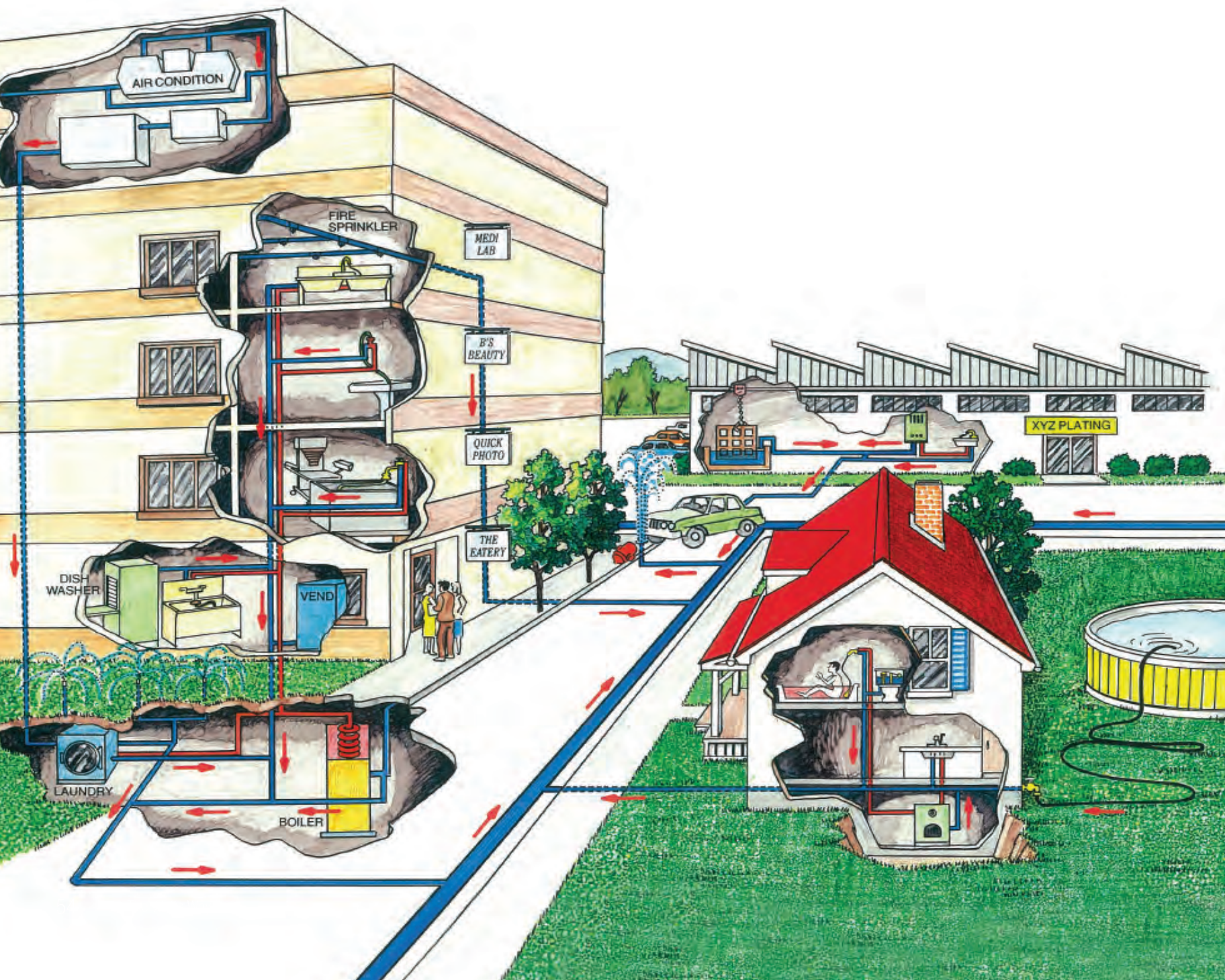

CHAPTER FIVE NEW PRODUCTS, NEW DIRECTIONS: 1972-1978

Even while Watts was making the case in court for T&P valves, it was preparing to do battle over the standards-setting process for another, ultimately more lucrative, valve market. George Horne had become interested in backflow preventers after he was approached by Colorado state sanitation inspectors. “They had problems with backflow and wanted to learn more about it,” he recalled. George Horne joined with representatives from other manufacturers in the plumbing and waterworks industries for a meeting in Denver to discuss and explain about various types and applications of backflow prevention with the Colorado inspectors.

Backflow is the reversal of the normal flow of water in a system. For example, opening a fire hydrant outside a home may create a vacuum in the house water-supply line and draw water out of the pipes back into the main supply. Such backflow may not present a threat to the drinking-water system unless the water line is connected to a source of contamination. This connection — most commonly through a simple garden hose — is called a “cross-connection” because it allows a supply line of potable water to be connected to a line that contains a contaminant. For example, a garden hose connected to a tank of swimming pool treatment chemicals represents a

potentially hazardous cross-connection. The Environmental Protection Agency (EPA) estimates that at least 100,000 cross-connections are made per day in the U.S.

From a technical standpoint, backflow breaks down into back siphonage and back pressure. Back siphonage occurs when pressure on the supply end of a potable water line drops precipitously, creating a vacuum that can suck fluids back into the system, such as when a fire engine draws water from a hydrant and creates a vacuum in the supply lines of nearby homes hooked to the same water main.

Back-pressure backflow occurs when water pressure on the outlet side of a line connected to potable water exceeds the supply pressure. Back-pressure backflow frequently involves a pump on the outlet end. In one case, an automatic car wash injected a strong detergent into a city water supply that flowed into homes more than a block away. Several cases have been recorded where improperly connected air conditioning circulating systems were cross-connected with city water supplies. One of the more sensational cases in recent history involved backflow into the air-conditioning system of the Bellevue Stratton Hotel in Philadelphia that resulted in conditions that fostered the growth of the bacteria that causes Legionnaire’s disease.

Opposite: This drawing illustrates areas of possible cross-connections and potentially polluted hazardous drinking water.

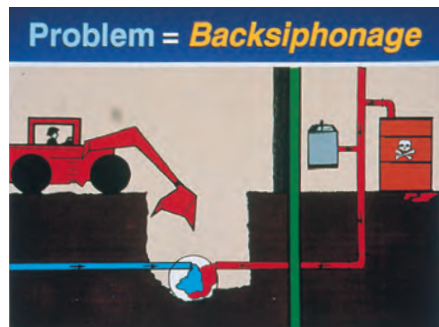

A drop in pressure on the supply of potable water creates a vacuum that can suck fluid back into the system, thereby producing the phenomenon of back siphonage.



The atmospheric vacuum breaker (No. 288) and the hose bibb vacuum breaker (No. 8) were valves manufactured and marketed by Watts Regulator for use in back-siphonage prevention.

In the early '70s, valve design for backflow prevention was still rudimentary. In 1970, Watts had little to offer for backflow prevention except a few vacuum breakers, but George Horne knew an opportunity when he saw it. "I came home and said, 'We're going to get into this market of making every kind of product that all these manufacturers make,'" he recalled. Watts began to gear up to produce not only the existing valve designs, but to build an innovative valve to accomplish the same task at a lower cost. Companies who were active in the backflow-prevention business, on the other hand, were already producing double-check valves and a cumbersome version of a valve known as the reduced pressure zone, or RPZ, valve.

The Colorado sanitation inspectors wanted to introduce a code requirement for backflow prevention. But before they could institute a code that required a particular backflow preventer, they had to be assured that competitive bidding for the code item would be possible. Only a handful of manufacturers were in the business, all producing an RPZ valve, as specified in a University of Southern California (USC) code. USC had developed a code because the potential for backflow contamination had been recognized primarily on the West Coast, in part because of experiences during World War II. On several occasions, large naval vessels had contaminated water supplies of port cities through backflow from their wastewater systems into the public drinking-water systems. But backflow problems were hardly confined to shipyard towns. In December 1970, a Cincinnati winery left a water-supply valve open after flushing out wine fermentation tanks. During a subsequent fermentation, a diluted sparkling burgundy must have backflowed from

the vats into the city supply line and ultimately out of the kitchen faucets of nearby homeowners. The fermentation tanks were operating at a higher pressure than the city water system. The resulting pink water was contaminated, though not dangerous.

Backflow contamination is generally less humorous and more hazardous. In a 1969 case, a maintenance man tried to unblock an air-conditioning coolant line with water pressure at a Pennsylvania college. Coolant flowed back into the water system, and unsuspecting students in other parts of the building drank the water, which was contaminated with chromates. In all, 23 people became ill.

Before Watts made a concerted effort to enter the backflow-prevention market with a full range of products, the company had made atmospheric vacuum breakers, which are used in systems where water flow is not continuous and never subject to back pressure. By breaking the vacuum, these valves prevent back siphonage. A simple and inexpensive form of vacuum breaker is the hose bibb vacuum breaker, which prevents back siphonage from garden hose sill cocks. For continuous water flow, a pressure-type vacuum breaker offers similar protection against back siphonage. Typically, these valves are used in low-flow applications such as trailer-park water connections, cattle-drinking fountains and laboratory equipment.

All of these backflow-prevention connections are relatively simple, inexpensive valves. But they do not protect against high-pressure backflow conditions, which require either double-check valve assemblies or reduced pressure-zone backflow preventers.

**Funeral Home
Water Cut Off
Due to Taint**

**AT BANK
Water Turns Pastel
As City Lines Cross**

The Cincinnati Post

TIMES AND STAR

NO. 295

22 Pages

WEDNESDAY, DECEMBER 24, 1969

WEATHER: More snow likely. Details, Page 4.

Wine, Not Water, Ran From Faucets

**Wells being
contaminated
by back-siphoning**

**They Turn On The Faucet
And Out Comes Gasoline**

**40 Sickened
By Water at
St. Joseph's
Chemical Leaks
From Air Cooler;
12 Are Hospitalized**

Although generally more hazardous than humorous, incidents of water contamination resulting from backflow occurred nationwide.

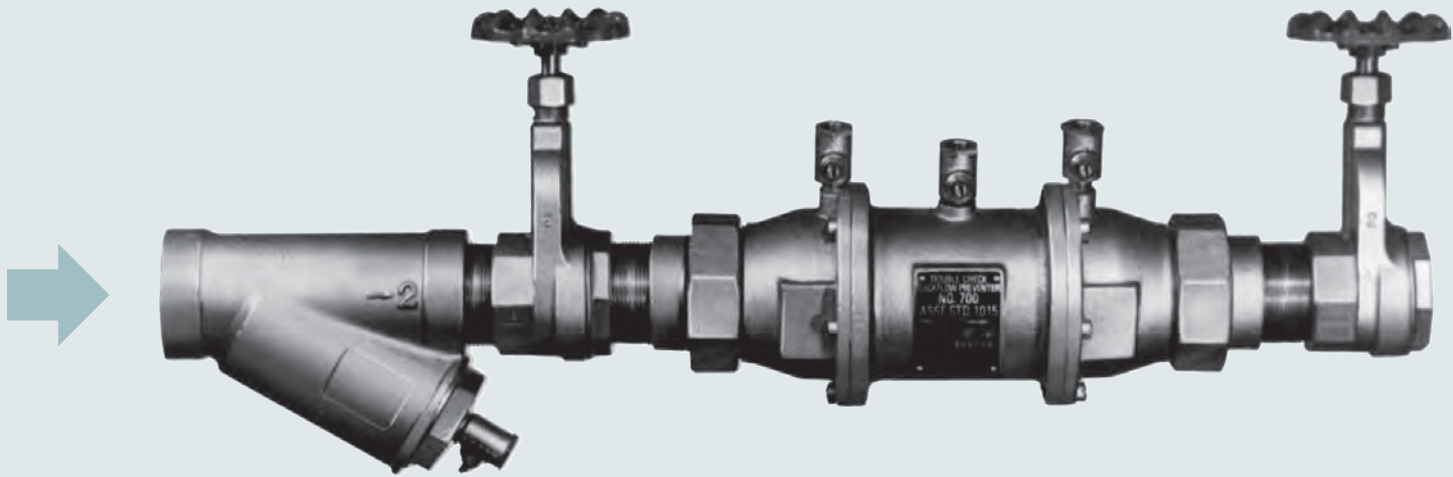

The double-check valve assembly contains two modular springloaded valves in series. Tension on the springs is adjusted to open the valves under normal supply pressures.

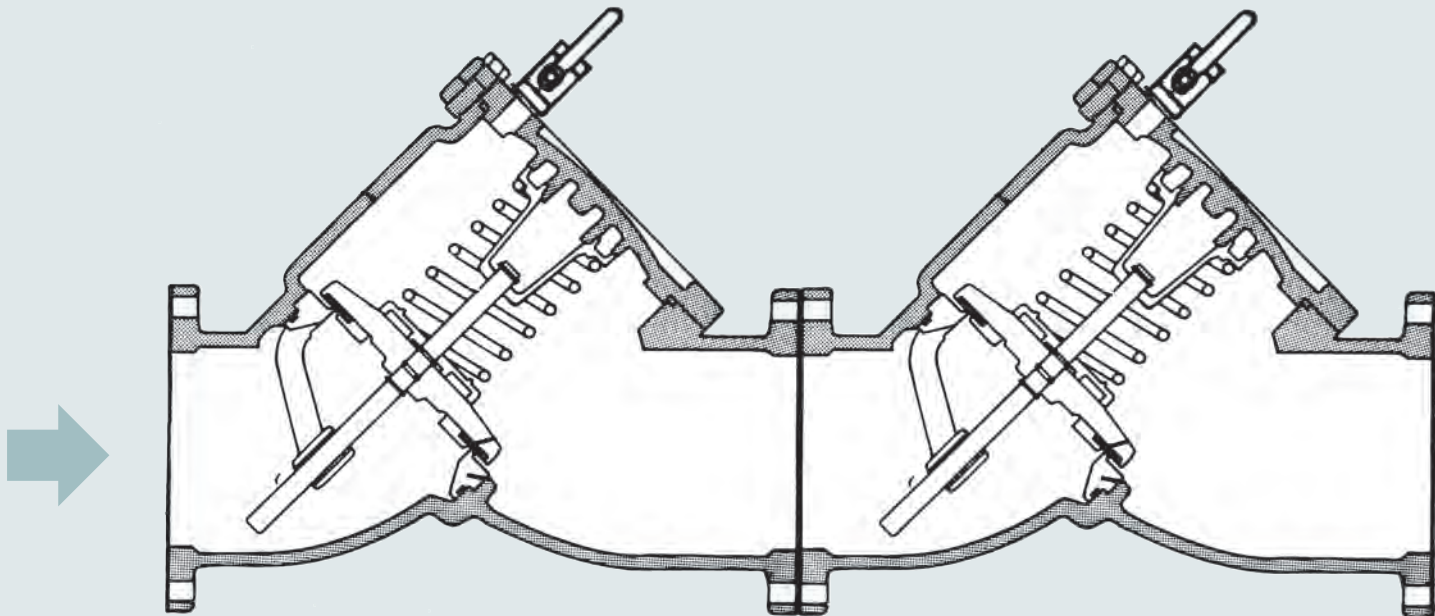

When a backflow condition occurs, the valves close. The shortcoming of the double-check valve assembly is that the valves can be fouled by sediment and fail to operate properly. As a result, double-check valve assemblies are approved only for low-hazard conditions — where the nonpotable side of the cross-connection may be only mildly contaminated.

Fig. 1
Illustrating the simple
Air-in/Water-out principle.

Basic Air-In/Water-Out Principle of
WATTS No. 909
Reduced Pressure Backflow Preventer

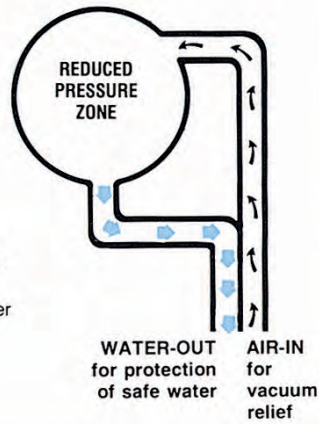
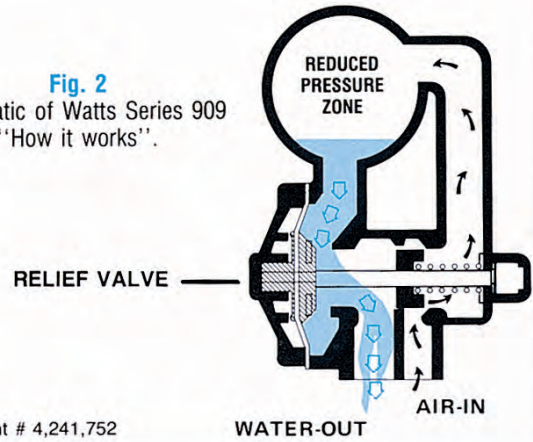

Fig. 2
Schematic of Watts Series 909
"How it works".



Patent # 4,241,752

Fig. 3 Back Siphonage

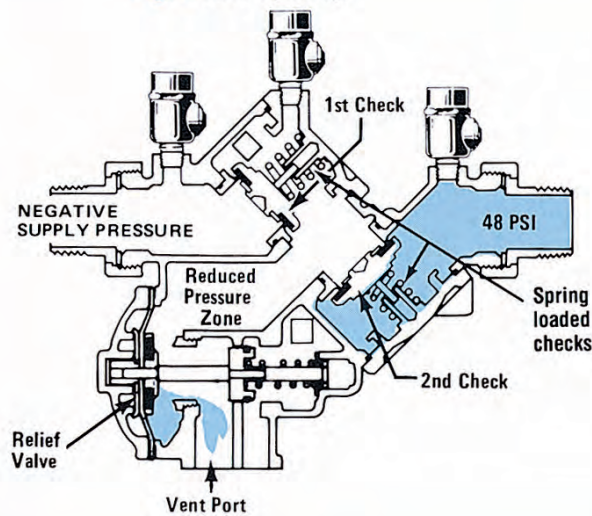
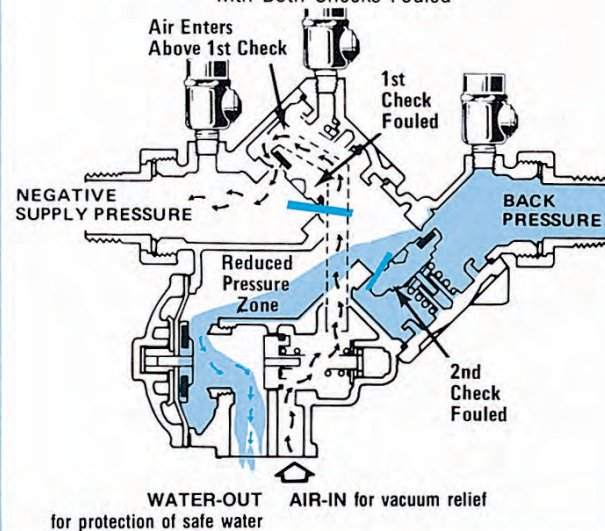
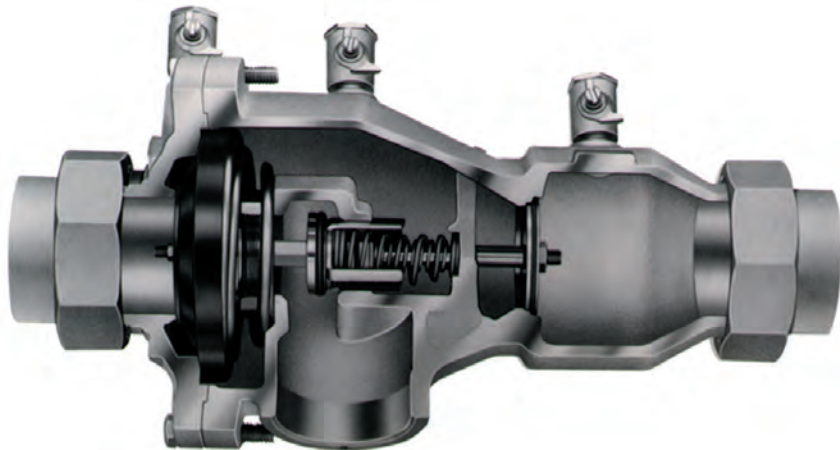

Fig. 4 Back Siphonage and Back Pressure
with Both Checks Fouled



The RPZ backflow preventer superficially resembles a double-check valve assembly, but spring tensions are adjusted to create an intermediate zone of pressure that is lower than the supply pressure. If back pressure builds up and the outlet valve fails, the buildup of pressure in the intermediate zone causes a relief valve to open and drain the entire assembly — preventing backflow to the supply line (see diagram). The RPZ backflow preventer is by far the most effective backflow preventer. It is the universally applicable solution for maximum protection and is commonly used in North America as a mainline connection to protect municipal water supplies and in situations in which a nonpotable fluid presents a health hazard.



The controversial model 900 backflow preventer designed by Watts was disputed by the University of California Foundation for Cross-Connection Control. Watts later modified the design to comply with the new USC specifications.

Determined to have Watts offer a full array of backflow-prevention products, George Horne put research and development into full swing, analyzing the products already in the market and looking for ways to redesign the RPZ preventers then available. George Horne rehired David Tine, a former head of engineering who had left Watts to go into business for himself. Because Tine worked closely with the testing laboratories for the fire insurance industry, he was somewhat familiar with backflow-prevention valves. The insurance industry standards group, Factory Mutual Test Laboratory, required backflow-prevention valves on sprinkler systems and other fire-safety systems. Only two companies were seriously in the business of making backflow preventers that met Factory Mutual's requirements — Hersey-Sparling Meter and Cla-Val, the former Clayton Valve Company.

George showed Tine drawings of existing RPZ valves. These were large, bulky assemblies in the design prevalent at the time, which called for large bronze castings with large internal chambers. George asked Tine to find a better design. Within a year, a radically new design of a reduced-pressure backflow-prevention valve emerged for testing at Watts. About half the size of competitive valves on the market, it met the criteria George Horne had hoped for. It was less expensive to produce and sell and took less installation space. The Watts Model 900 Backflow Preventer, as it was called, was to become the subject of a bitter dispute between Watts and the University of California Foundation for Cross-Connection Control.

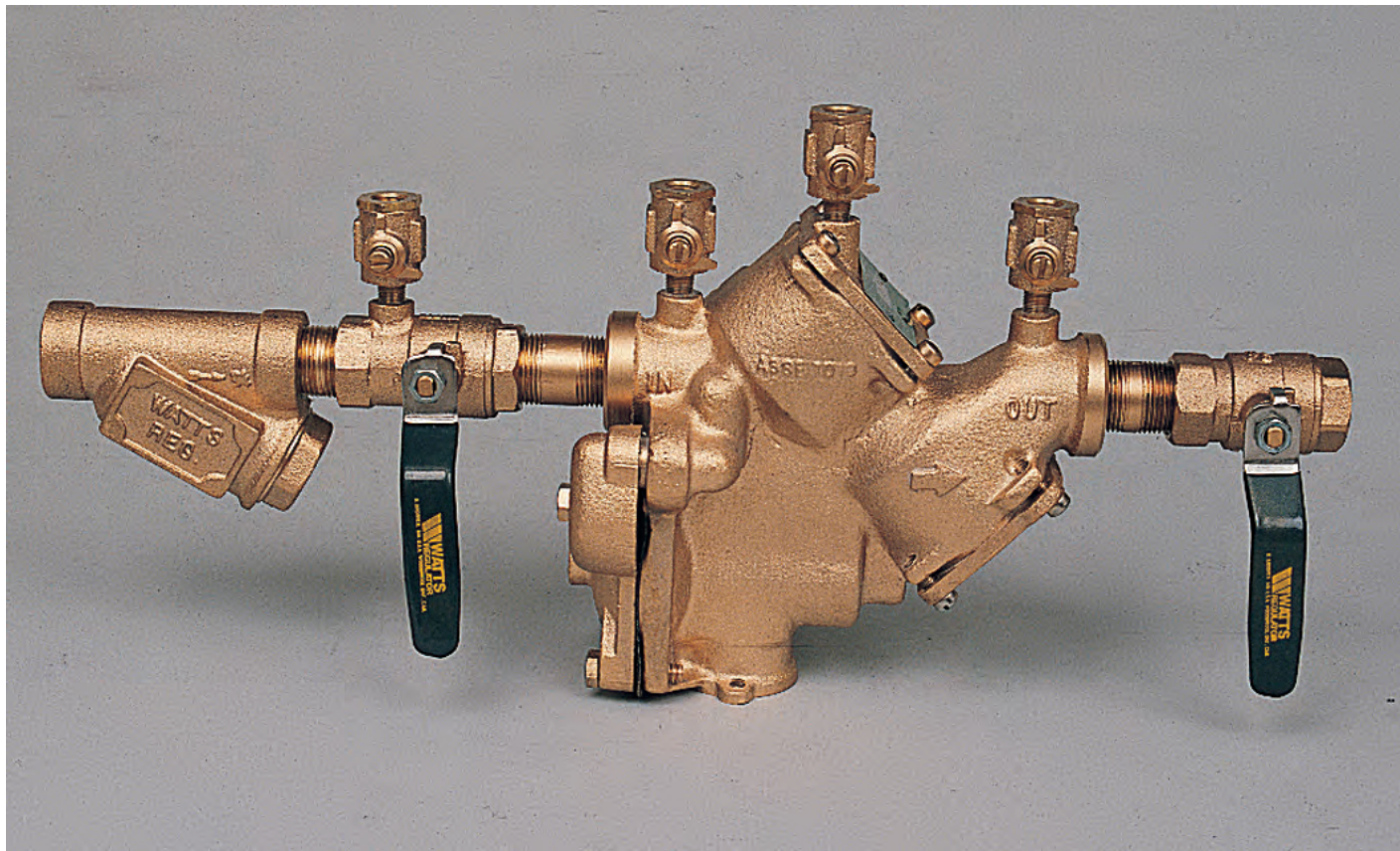

Watts Regulator worked closely with the American Society of Sanitary Engineering (ASSE), who set standards for specific types of backflow preventers, ensuring that its products met or exceeded these requirements. The Model 909 RP was accepted by both the American Water Works Association (AWWA) and the ASSE.

Because backflow prevention had emerged as a concern on the West Coast, engineers at USC had been the first to turn their attention to setting standards for backflow-prevention valves. A USC professor had literally written the book on the subject, “The USC Manual for Cross-Connection Control.” Although the USC standard lacked the force of law, it had been adopted by municipalities and some states because it was the pre-dominate specification standard around for backflow prevention. That suited the university, and it suited the handful of manufacturers with USC approval. But from Watts’ perspective, the de facto USC standard was less than satisfactory

because rather than specify performance standards, it dictated how to design the backflow preventer.

In 1972, the Model 900 ran afoul of the USC approval process. The first reason given for not approving the Model 900 was that it could not be serviced without removing it from the water line. But the AWWA Standard C506 for backflow preventers specifically exempted small devices (3/4” to 2”) from in-line service requirements. USC also refused to approve the Model 900 because it did not drain to a low-enough level for extreme applications in very hilly terrain. The drain level had not been specified

in previous performance standards, but USC saw fit to exclude the Model 900 design.

While the feeling at Watts was that USC’s refusal to accept the Model 900 design was based on fear that the new design would hurt existing manufacturers (whose products were heavier and more than twice as expensive), Watts nonetheless modified the design to meet new USC specifications. The result was the Model 909 RP (for reduced pressure) backflow preventer. But the original Model 900 had broken the ice. Backflow preventers did not have to be cumbersome nor prohibitively expensive.

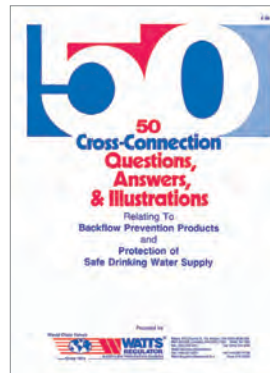

Watts provided plumbing inspectors, as well as plumbers, with specialized training sessions on the proper use of backflow-prevention devices. It also provided a wide variety of training and educational materials to local waterworks.

The creation of a complete line of backflow preventers marked Watts' movement into the waterworks industry. The company joined the AWWA and the ASSE in order to participate in their code-making processes. The AWWA's standard for RPZ backflow preventers accepted the Model 900, and AWWA's standard was the one that mattered to most municipal waterworks. (Eleven western states continued to follow the lead of USC, which approved the Model 909 RP, as did every other standards group.) ASSE set standards for each type of backflow preventer, and Watts worked closely with the organization to ensure that its backflow preventers met or exceeded ASSE standards. By courting all the standards

setters, Watts became a leader in the backflow-prevention field. That position was enhanced by Watts' education efforts, which included the publication of "Stop Backflow News," a series of case histories begun in 1971, even before Watts had developed a complete backflow-prevention line.

Growing understanding of the hazards of backflow also helped Watts' stature in the industry. In 1974, Congress passed the Safe Drinking Water Act, which led to regulatory mandates for cross-connection control programs. In the early 1970s, the insurance industry also began to recognize the importance of backflow prevention and began to exclude backflow from liability insurance

coverage as a result of some contamination cases. The Safe Drinking Water Act went beyond protecting public water supplies from contamination; it also required local waterworks to educate the public on the hazards of backflow and how to prevent it. As it had with T&P valves, Watts geared up to produce a wealth of educational and training materials that waterworks could use to meet their mandate. Likewise, Watts provided training sessions for plumbers and plumbing inspectors on the proper use of backflow-prevention devices. This energetic backflow-prevention program paid off handsomely for Watts. The company now leads the field in the U.S.



Watts became a leader in the backflow-prevention field, a position complemented by its burgeoning education efforts, which included a series of case history publications, "Stop Backflow News," that first appeared in the early 1970s.

The evolution of products in a new direction was not the only change going on at Watts. In 1976, Tim Horne became president of the company. In 1978, George Horne retired and Tim Horne became both president and chief executive officer (CEO). The transition to the third generation of Horne management was completed.

Tim Horne's first gamble was to go beyond plumbing, heating and waterworks into the industrial market. The Watts Fluid Power Division was sold, and the proceeds were used to develop a line of industrial ball valves. "The departure into the entirely different world of the industrial market was a dramatic entree by Watts into a market that had been foreign to the company," Tim Horne recalled. "But ball valves got us into the chemical processing industries, primarily, and into other processing industries in general."

The foray into industrial valves was wrenching for many of Watts' sales representatives. Watts asked its existing plumbing and heating sales representatives to hire additional people who would be suitable to call on industrial distributors rather than plumbing and heating distributors. "Most of them had very mixed results," Tim Horne recalled. "Some sold no valves to the industrial sector. Most of the balance sold a mixed bag."

So, Watts gradually took the industrial ball valve market away from all but the most successful plumbing and heating representatives. The process of establishing the credibility to attract the top industrial sales representatives and distributors, said Tim Horne, took the better part of a decade. The hard road of developing the ball valve line thus made a strong impression on Tim Horne. Watts had gone as far as it could in developing new product lines by itself. The future, he believed, lay in the acquisition of complementary companies.



The marketing of the Watts line of industrial ball valves enabled the company to gain access to the chemical processing industry.



CHAPTER SIX SETTING THE STAGE: 1978-1984

Also in 1978, Tim Horne began a push to reshape the top management team of Watts Regulator by hiring personnel who would bring new ideas and outside experience to the company. Expansion meant more than investing in new products; it also meant investing in top management skills. Horne had already decided to enter the industrial ball valve market, and his first need was a head of manufacturing who would have a mastery of the challenges inherent in working in high-carbon and stainless steel rather than the brass and bronze alloys with which Watts was so familiar. Watts had never shirked in development of new products, but those products had almost always been extensions of existing expertise and almost invariably were made in brass and bronze. Much of the new line of industrial ball valves, however, had to be designed in ferrous metals, which required new machinery, new tooling and personnel knowledgeable in manufacturing industrial products. In the fall of 1978, Tim Horne hired Robert T. McLaurin as the new vice president for manufacturing.

McLaurin's background included stints as head of engineering and in general management for several major valve manufacturing companies. When the two men met, it was an instant fit. Tim Horne articulated his vision of expanding Watts Regulator into new markets

through the development of entirely new product lines and explained how he intended to finance that growth. McLaurin saw a challenge that would draw on all his expertise. Not only did the company need to develop new product lines, it was also ripe for a rejuvenation of its approach to manufacturing. Moreover, Watts Regulator was positioned well financially for a leap ahead. When McLaurin started work on October 1, 1978, Watts Fluid Power had already been sold and the company had taken other financial measures that freed cash to turn Tim Horne's plans into reality.

"When I first heard about Watts," McLaurin admitted, "it didn't excite me a lot. Here was a company that had been making plumbing and heating products for a long time. But Tim had a vision for Watts that included more engineered products and aggressive growth. His attitude was that we knew what to do and we should do it. And that's the way it's been ever since. I've never had to spend a lot of time convincing him that we should do things the right way. It's a given at Watts that 'the right way' is the only way." McLaurin described his task in part as elevating Watts Regulator's manufacturing operations to include state-of-the-art equipment (computerized numerical control machining centers and lathes) comparable to the best anywhere in the manufacturing sector.

Opposite: Most of the industrial ball valves in the new line were composed of ferrous metals, which necessitated new machinery and tooling.



Striving to reshape the top management team at Watts, Tim Horne hired **Robert T. McLaurin** as vice president for manufacturing in 1978. His experience in engineering and manufacturing management was paramount to the successful expansion of Watts Regulator.

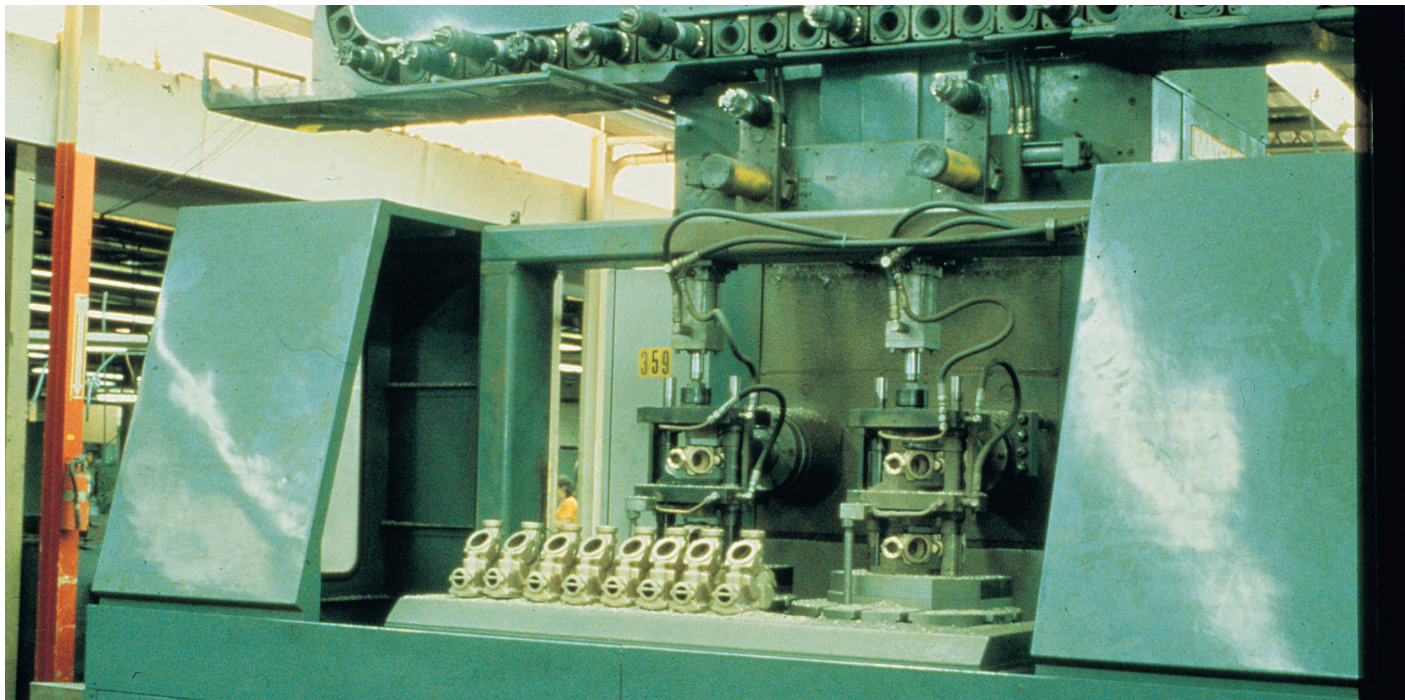

A believer that the “right way” is the only way, McLaurin upgraded Watts Regulator’s manufacturing operations to include state-of-the-art equipment such as this computerized numerical control machining center.

Horne and McLaurin sought to hire a few key outside people and focused on extensive training for existing personnel. Hiring a supervisor with manufacturing expertise from a competing ball valve company was the first step.

Although Watts was perhaps the most efficient valve manufacturer in the plumbing and heating products industry, its equipment and organization were not oriented to industrial operations. The company had just built a new manufacturing facility in Spindale, North Carolina, but its manufacturing flagship operation was still the facility in Franklin, New Hampshire. McLaurin turned his attention first to Franklin. “We needed to buy equipment and tooling, and to hire people,” McLaurin recalled. “The hardest

part, however, was making changes on the floor and in manufacturing engineering.” McLaurin brought in Watts’ first computerized numerical control equipment. It was not a lightly made decision. “For example, we bought a \$320,000 piece of equipment even though we couldn’t keep it busy for one shift five days a week,” he said. “However, we had high expectations for future orders. In two years, we had that machine busy five days a week for three shifts and we went out and bought another one.” Watts’ traditional willingness to spend money to make money was paying off.

McLaurin cited changes in tooling and floor practices for increased efficiencies

as well. “We had jobs that we did in nine operations, moving the piece from one equipment station to the next. We ended up processing in one single setup where we didn’t have to handle it several times. Other machines operated singly with idle time in between, so we grouped them in what’s now called the ‘cell’ concept.”

At the same time, McLaurin also introduced a new quality control technique designed to trim waste and guarantee top-quality products — a material review board, or MRB. As scrap was generated, it was assembled in a specific area at the end of each day, where the members of the MRB would go over each piece to establish why it was spoiled, how to prevent future waste and to evaluate how a piece might be reworked.

Next page: Webster Valve remained the chief manufacturing facility, while McLaurin executed changes in tooling and floor practices to increase efficiency.







Watts built a new manufacturing plant in Spindale, North Carolina. The North Carolina plant came into its own as the center for high-volume plumbing and heating products, freeing up some space and personnel at the Franklin, New Hampshire, plant, which could then focus on industrial products.



Watts repeated a successful strategy and constructed a bronze foundry at the Spindale plant.

As the industrial ball valve business began to move from development into production — a complete line was established in less than four years — the North Carolina plant came into its own as the center for high-volume plumbing and heating products, freeing up space and personnel at the Franklin, New Hampshire, plant, which could then focus on industrial products. “We made Webster Valve [in Franklin] the center for development of the new engineered products,” said McLaurin.

And as the Spindale plant began to expand, Watts repeated one of its successful strategies from New England: the construction of its own bronze foundry, as it had done several years before in Franklin, New Hampshire. The advantages of having a company-owned foundry were both financial and strategic. Producing its own castings allowed Watts to pocket the middleman’s profit, and it also meant being able to control quality and to adjust foundry production as customer demand warranted.

The recasting of Watts’ manufacturing capabilities paid off handsomely. Sales rose from \$39.5 million in 1978 to \$66 million in 1981. In the same period, net earnings grew from \$2 million to \$5.2 million, an increase of 160%. By 1984, when Watts’ sales finally topped \$100 million, ball valves and actuators represented 18% of sales.



By producing its own castings, the bronze foundry at Spindale was able to eliminate the outside supplier, thereby operating more cost-efficiently through such vertical integration.

But it was clear even by 1981 that the dramatic growth envisioned by Tim Horne could not be sustained indefinitely through internal expansion. He began to look at other options, such as making major acquisitions and going public to raise investment capital. Whatever road the company took, however, would require an overhaul of its financial record-keeping as fundamental as the changes McLaurin had brought to its manufacturing operations. In particular, the books had to be brought into line with the conventions of Securities and

Exchange Commission (SEC) standards for publicly owned companies.

In August 1981, Kenneth J. McAvoy joined Watts as controller, reporting to the vice president of finance. “At that point,” said McAvoy, “the books hadn’t been closed for June and I immediately realized that accounting had very little sense of direction or coordination with what was going on in the rest of the company. Our chief bookkeeper had no idea how the numbers that went in the books related to anything else in the

company, and to everyone else, we were merely a necessary evil — the bean counters.”

When McAvoy interviewed for the job, Tim Horne had told him that the twin needs for family liquidity and ambitious growth required raising funds by taking the company public. Moreover, Bessemer Securities had taken a significant minority position in 1981 with exit privileges in 1986. “One way to handle Bessemer’s exit privilege was to go public,” McAvoy realized.



In August of 1981, **Kenneth J. McAvoy** joined Watts Regulator as controller, reorganizing the accounting department to operate in keeping with the rest of the company.

To move toward the financial reporting formalities of public ownership, McAvoy began to implement changes in internal reporting practices. “Because Ernst & Whinney was auditing the financials, Watts was already 80% in compliance with the standard reporting requirements,” McAvoy said, “but the figures were translations at the end of the year from a different system of postings.” The company had always been publicly audited, but SEC requirements would mean a series of reclassifications. At the time, the auditing firm examined the books at the end of the year and made allocations of fixed and variable costs and reported accordingly. McAvoy introduced full-absorption accounting at all stages of Watts’ bookkeeping — not just to make the year-end audit process simpler, but also to capture the power of accounting as a management tool.

Full-absorption accounting distributes costs as fixed, variable, or semivariable. Equipment capital cost, for example, is generally stated as a fixed cost in that a machine costs the same whether it is producing 10 units or 50 units per hour. (Maintenance, repair and power, however, are all variable costs that depend on how heavily the machine is used.) Materials are variable because they are directly related to volume of production. Labor is semivariable in that production can vary considerably within a given workforce depending on idle time, production floor efficiencies and volume of orders.

Next page: Labor qualifies as “semivariable.”

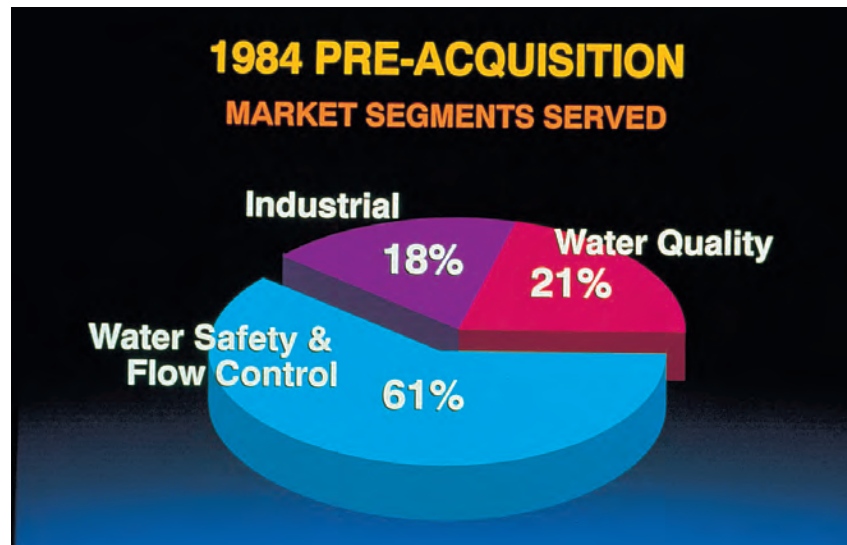

In 1984, Watts’ sales exceeded \$100 million with 18% representing ball valve and actuator sales.

WATTS REGULATOR COMPANY Product Line Analysis (000's Omitted)												
Description	Sales	% To Total	Direct Cost	% To Sales	Direct Cost	% To Total	Full Absorb Cost	% To Sales	Full Absorb Incent	% To Total	Net Cost	% To Total
PERIOD Month of May 1981												
Temperature & Pressure Relief Valves	1537	25.8	762	50.0	775	23.4	905	58.9	143	9.1	632	23.5
Pressure Relief Valves	418	7.0	156	37.2	280	8.5	174	41.6	38	9.1	242	9.0
Backflow Preventers	1422	23.9	510	35.9	932	27.6	711	50.0	201	14.1	711	26.4
Reducing Valves	1034	17.4	298	28.8	736	22.3	388	37.5	60	5.7	646	24.0
Ball Valves	1004	16.9	578	57.7	425	12.8	718	71.5	139	13.0	286	10.4
Hydraulics	14	.2	4	28.6	10	.3	6	42.9	2	14.3	8	.3
Tempering Valves	177	2.9	47	26.6	130	3.9	64	36.2	17	9.6	113	4.2
Steam Regulators	103	1.7	34	33.0	69	2.1	30	48.5	18	19.3	53	2.0
Parts	187	3.1	92	51.9	90	2.7	110	58.8	13	7.0	79	2.9
Miscellaneous	334	5.6	148	44.8	286	8.8	187	52.6	39	11.0	147	5.2
Regul Products	-	-	-	-	-	-	-	-	-	-	-	-
Misc. Sales Adjustments	(290)	(4.9)	34	-	(324)	(9.8)	(45)	(15.5)	(79)	(27.2)	(245)	(9.1)
Grand Total	5955	100.0	2640	44.2	3309	55.0	3268	54.9	619	10.4	2690	45.2
PERIOD Year-to-Date May 1981												
Temperature & Relief Valves	12566	22.2	6602	52.5	3864	19.1	7551	60.1	949	7.6	5015	20.5
Pressure Relief Valves	4615	8.2	1594	34.5	3021	9.7	2075	45.0	481	10.4	2540	10.4
Backflow Preventers	12275	21.7	4491	36.6	7784	25.0	6067	49.4	1576	12.8	6208	25.4
Reducing Valves	9094	15.6	2662	29.3	6432	21.5	4183	46.0	1801	19.1	5731	23.6
Ball Valves	9386	16.4	5356	57.0	3830	12.3	6498	73.5	1362	14.3	2488	10.2
Hydraulics	417	.7	143	34.3	274	.9	209	50.1	66	15.8	208	.8
Tempering Valves	1324	2.3	377	28.5	947	3.0	509	38.4	132	10.0	815	3.2
Steam Regulators	984	1.7	358	36.4	626	2.0	536	54.3	178	18.1	448	1.8
Parts	2289	4.0	1409	61.4	880	2.8	1617	70.6	208	9.1	672	2.8
Miscellaneous	3294	5.6	1380	41.9	1918	6.1	1780	54.0	400	12.1	1518	4.2
Regul Products	146	.3	59	40.4	87	.3	34	23.3	1	.7	86	.4
Misc. Sales Adjustments	(848)	(1.4)	255	-	(104)	(3.2)	(74)	-	(44)	-	(1353)	(5.1)
Grand Total	56505	100.0	25382	44.9	31223	55.1	32165	56.9	6893	12.2	24272	42.8

Moving toward the financial formalities of public ownership, McAvoy effected dramatic changes to the existing reporting practices. He introduced full-absorption accounting at all stages of Watts’ bookkeeping, illustrating the significance of accounting as a management tool.





E

KEYSTONE
NEVADA
9016A00
2439

Such careful accounting reveals the actual cost of maintaining inventory — a thorny question that had been the focus of many a dispute between George and Burchard Horne a generation earlier. For example, under the full-absorption system, all manufacturing overhead was captured in product cost. Previously, inventory had been undervalued because these certain fixed costs were not assigned to the product. The carrying costs of inventory include lost income from the capital tied up in inventory as well as the more visible costs of warehousing, stock-room personnel and obsolescence. As a positive cash-flow generator, Watts has been able to carry inventory at reasonably high levels. By having much of its inventory of finished products located at commissioned agents' warehouses, the

company significantly reduces the direct carrying costs of inventory and provides the opportunity to capture immediate sales. If a customer needs a valve, it would likely choose the brand that was available over the brand that would take two weeks to arrive.

Upgrading the financial staff became one of McAvoy's immediate concerns, in particular upgrading the individual controllers at Watts' manufacturing plants. McAvoy said that in his first year, he typically spent a day a week at the Franklin, New Hampshire, plant and a day a month in Spindale, North Carolina, overseeing and reorganizing the accounting. By hiring new plant controllers, whose chief responsibility was manufacturing accounting for their

facilities, he was able to cut back to quarterly visits to the New Hampshire plant and semiannual visits to North Carolina and Watts Canada.

In 1984, McAvoy became vice president of finance. In three years, he had created a track record for Watts of accounting by SEC standards by reorganizing the corporate accounting department to prepare for reporting as a public company and to be poised to handle the analysis necessary to acquire other companies and bring their profitability into line with the impressive Watts' standard. Watts Industries was ready to begin preparations for its 1986 public stock offering, the first since the company had been founded more than a century earlier.



Guided by a team of professionals, Watts Industries was prepared for its initial public stock offering, the first since the company's birth more than 100 years earlier.

*This announcement is neither an offer to sell nor a solicitation of an offer to buy these securities.
The offer is made only by the Prospectus.*

4,500,000 Shares



Watts Industries, Inc.

Class A Common Stock

Price \$16½ per Share

Copies of the Prospectus may be obtained in any State only from such of the several Underwriters, including the undersigned, as may lawfully offer the securities in such State.

Shearson Lehman Brothers Inc.	Donaldson, Lufkin & Jenrette <small>Securities Corporation</small>		
Dillon, Read & Co. Inc.	The First Boston Corporation	Bear, Stearns & Co. Inc.	
Drexel Burnham Lambert <small>Incorporated</small>	Goldman, Sachs & Co.	Hambrecht & Quist <small>Incorporated</small>	
Kidder, Peabody & Co. <small>Incorporated</small>	Lazard Frères & Co.	Merrill Lynch Capital Markets	
Montgomery Securities	Morgan Stanley & Co. <small>Incorporated</small>	PaineWebber <small>Incorporated</small>	
Prudential-Bache <small>Securities</small>	Robertson, Colman & Stephens		
L. F. Rothschild, Unterberg, Towbin, Inc.	Salomon Brothers Inc		
Smith Barney, Harris Upham & Co. <small>Incorporated</small>	Wertheim & Co., Inc.	Dean Witter Reynolds Inc.	
Allen & Company <small>Incorporated</small>	William Blair & Company	A. G. Edwards & Sons, Inc.	
Oppenheimer & Co., Inc.	Rothschild Inc.	Thomson McKinnon Securities Inc.	
Advest, Inc.	Arnhold and S. Bleichroeder, Inc.	Robert W. Baird & Co. <small>Incorporated</small>	
Bateman Eichler, Hill Richards <small>Incorporated</small>	Sanford C. Bernstein & Co., Inc.		
Blunt Ellis & Loewi <small>Incorporated</small>	J. C. Bradford & Co. <small>Incorporated</small>	Cowen & Co.	Dain Bosworth <small>Incorporated</small>
Doft & Co., Inc.	Eberstadt Fleming Inc.	Foster & Marshall Inc.	
Janney Montgomery Scott Inc.	Ladenburg, Thalmann & Co. Inc.		
Cyrus J. Lawrence <small>Incorporated</small>	Legg Mason Wood Walker <small>Incorporated</small>	McDonald & Company <small>Securities, Inc.</small>	
McLeod Young Weir Incorporated	Morgan Keegan & Company, Inc.		
Moseley Securities Corporation	Neuberger & Berman	The Ohio Company	
Piper, Jaffray & Hopwood <small>Incorporated</small>	Prescott, Ball & Turben, Inc.		
The Robinson-Humphrey Company, Inc.	Stephens Inc.	Stifel, Nicolaus & Company <small>Incorporated</small>	
Tucker, Anthony & R. L. Day, Inc.	Wheat, First Securities, Inc.		
Adams, Harkness & Hill, Inc.	Burns, Pauli & Co., Inc.	First Albany Corporation	
Johnson, Lane, Space, Smith & Co., Inc.	McKinley Allsopp, Inc.		
Needham & Company, Inc.	Swergold, Chefitz & Sinsabaugh, Inc.		

August 26, 1986



CHAPTER SEVEN

WATTS INDUSTRIES ACQUISITIONS: 1984-1993

Once the industrial ball valve line began to develop at the Franklin, New Hampshire, plant, Tim Horne faced a dilemma. Watts Regulator's plumbing and heating business was mature. There would still be room to add innovations to the product lines, but Watts had largely saturated the plumbing and heating markets. The ball valve venture, however, "proved that we could go into a new market and that made us think about getting into other markets," explained Tim Horne.

The question was how to expand — by starting new product lines from scratch or by acquiring smaller companies that were already entrenched in niche markets? Bessemer Securities, which had become a minority investor in Watts Regulator in 1981, and Tim Horne came to an agreement: Watts would begin looking aggressively for acquisitions.

Acquiring companies and blending them into an existing operation is something of an art, and Watts needed someone with experience in the process. Moreover, the growing company required someone with extensive industrial experience. In 1983, Horne found his man: Charles Grigg, who was running a competing industrial ball valve company, Worcester Controls. Grigg had worked for British Tire & Rubber, making acquisitions, before he had settled into running Worcester Controls.

"Watts was selling into the low end of the industrial market then," Grigg recalled. "It got us in the door, but the profit numbers at first were marginal. So Tim was looking for help on the industrial side. At the same time, I had acquisitions

experience. We both proceeded very cautiously, though. Watts was a \$77 million company, mostly in plumbing and heating valves, and moving into new areas was a major step. But Tim and I both saw that to expand, we needed to go beyond plumbing and heating."

Tim Horne recalled, "It took us a year to find our first acquisition. Spence Engineering came to my attention through Bessemer [the minority investor in Watts]. The last surviving daughter of the founder, who had inherited the company, had died. It was an estate sale. We pre-empted any other interested parties and by moving fast, it was done, start to finish, in about 120 days."

Ironically, Tim Horne had told Grigg when he came aboard in November 1983 that steam should be the company's first acquisition. Only a few months later, Bessemer called to see if Watts was interested in Spence, which specialized in steam. "I knew steam was very popular because we still sold some steam valves in the big Watts catalog and at gross margins over 50%," Tim Horne said. Steam valves tend to carry a fairly high gross profit margin because steam is a hazardous fluid. Although some plumbing and heating valves are commodity products, most steam-control valves are built to demanding engineering specifications. The customer pays for performance, not the cost of materials. Acquiring Spence brought Watts full circle back into the high-performance steam market that it had ceded during the Depression — to Spence and others — to concentrate on plumbing and heating valves. Over the years, the company's specialization had become 85% plumbing.

Opposite: Watts Regulator's new corporate headquarters.



After a one-year search, Watts found its first acquisition, Spence Engineering, which reintroduced the company to the high-performance steam market after a 50-year hiatus.



Since steam is considered to be a hazardous fluid, steam valves generally carry a high gross profit margin. Most steam-control valves are built to comply with demanding engineering specifications, such as this type D152A Direct Pressure Reducing Regulator designed and manufactured at Watts.

Spence was not a large company — it had \$6.7 million in sales when Watts acquired it in 1984 — but it represented an important niche. It had more than half the market for pilot-operated steam regulators. “Spence brought us more dramatically into heating — the HVAC market — as well as more industrial valves,” Tim Horne observed. “Some of these steam regulators that Spence manufactures are used on process steam lines. That added to our marketing arena. Steam is a very effective medium for power generation as well as other industrial processes.”

It was also a terrific deal for Watts. As Grigg recalled, “The president of Spence really wanted to sell to Watts. He could see what it would do for his operation. We were able to work out a financially creative deal where we put up very little cash and financed 75% of the purchase price with industrial bonds. And it’s been a jewel of a company. We’ve grown it from \$6.7 million in sales to \$14 million while maintaining high gross margins.”

Toward the end of the year, Watts also seized the opportunity to purchase Hale Oilfield Products, a small company. Again, it was a valve company in an area where Watts would have been hard-pressed to develop its own line and establish a foothold in the market. As a provider of valves for the oil and gas pipeline industry, Hale tended to be volatile in its earnings, making more money when the energy industry boomed and less when the oil business was soft. But the company was small, and purchasing it meant little financial exposure.



Watts Regulator's new corporate headquarters, designed by **Frederick Horne**, corporate vice president, was completed in 1985. The contemporary building allowed plenty of room for expansion, reflecting Watts' eye toward continuing growth.



As Watts pursued business acquisitions, it also searched for a knowledgeable and experienced person with an extensive industrial background. In 1983, **Charles Grigg**, skilled in both management and making acquisitions in the industrial field, joined the company.

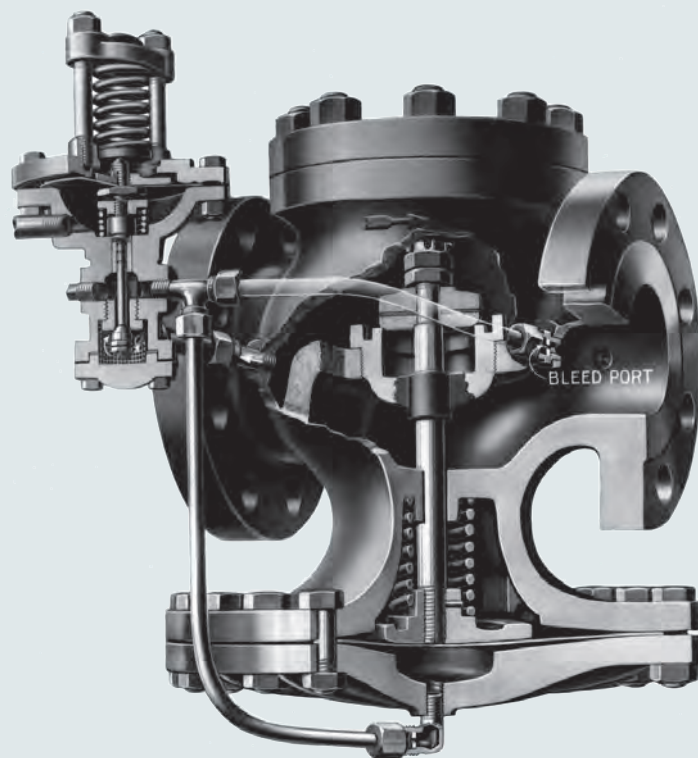

Spence had half the market for pilot-operated steam regulators, some of which were used on process steam lines.



Although Hale Oilfield Products was a small company, it generated a variety of valves, parts and accessories utilized by the oil and gas industry.

Watts did not make acquisitions during 1985, as the company was restructuring its management team and preparing for its first public stock offering, which finally took place at the end of August 1986. That spring, Tim Horne became chairman of the board and CEO of Watts Industries, Inc. Charles Grigg became president and chief operating officer (COO) at the same time. By the end of the summer, the offering was ready. The firms of Shearson Lehman Brothers Inc. and Donaldson, Lufkin & Jenrette Securities Corporation were the primary underwriters for the initial offering of 4.5 million shares of Class A common stock. Shares of Watts Industries, trading as WATTA on the NASDAQ exchange, were offered at \$16.50 per share.

But Watts had only paused in its acquisition program. The offering prospectus stated, "The Company is not presently engaged in discussions or negotiations nor has it reached any agreements or understanding concerning possible acquisitions." In 1986, however, Watts Industries did acquire the James Jones Company, a business that resembled Watts Regulator in many ways. It had been founded in 1892 by an English-born journeyman pipe fitter and machinist. Unlike Watts, this family-owned firm remained regional in scope and specialized in the related but distinct field of supplying bronze valves to the waterworks industry. Watts had grown to encompass most plumbing on the inside of buildings; James Jones covered the underground water pipeline service.

PROSPECTUS

4,500,000 Shares

Watts Industries, Inc.
Class A Common Stock

Of the shares of Class A Common Stock offered hereby, 1,000,000 shares are being offered by the Company and 3,500,000 shares are being offered by the Selling Stockholders. The Company will not receive any of the proceeds from the sale of shares of Class A Common Stock by the Selling Stockholders. See "Principal and Selling Stockholders."

Prior to this offering, there has been no public market for any class of capital stock of the Company. See "Underwriting" for a discussion of the factors considered in determining the initial public offering price to the public.

THESE SECURITIES HAVE NOT BEEN APPROVED OR DISAPPROVED BY THE SECURITIES AND EXCHANGE COMMISSION NOR HAS THE COMMISSION PASSED UPON THE ACCURACY OR ADEQUACY OF THIS PROSPECTUS. ANY REPRESENTATION TO THE CONTRARY IS A CRIMINAL OFFENSE.

	Price to Public	Underwriting Discounts and Commissions (1)	Proceeds to Company (2)	Proceeds to Selling Stockholders (2)
Per Share	\$16.50	\$0.90	\$15.60	\$15.60
Total (3)	\$74,250,000	\$4,050,000	\$15,600,000	\$54,600,000

(1) The Company and the Selling Stockholders have agreed to indemnify the Underwriters against certain liabilities, including liabilities arising under the Securities Act of 1933. See "Underwriting."

(2) Before deducting expenses estimated at \$427,228, of which \$93,990 is payable by the Company and \$333,238 is payable by the Selling Stockholders.

(3) Certain of the Selling Stockholders have granted the Underwriters an option to purchase up to 675,000 additional shares of Class A Common Stock for the purpose of covering over-allotments at the Price to Public noted above. See "Underwriting." If such option is exercised in full, the total Price to Public, Underwriting Discounts and Commissions and Proceeds to Selling Stockholders will be \$85,387,500, \$4,657,500 and \$65,130,000, respectively.

The shares of Class A Common Stock offered by this Prospectus are offered by the Underwriters subject to prior sale, to withdrawal, cancellation or modification of the offer without notice, to delivery to and acceptance by the Underwriters, and to certain other conditions. It is expected that delivery of certificates for the shares of Class A Common Stock will be made at the offices of Shearson Lehman Brothers Inc., New York, New York, on or about August 28, 1986.

Shearson Lehman Brothers Inc. Donaldson, Lufkin & Jenrette
Securities Corporation

August 21, 1986

At the end of the summer of 1986, the prospectus for the initial public offering was prepared with Shearson Lehman Brothers Inc. and Donaldson, Lufkin & Jenrette Securities Corporation as the primary underwriters.

Tim Horne had learned of the James Jones Company when he had tried to purchase a competing company. “I did my best and I could see I wasn’t going to get it. So I asked, ‘Who’s your most pesky competitor in the western part of the country?’ They said, ‘James Jones.’” He asked Grigg to call the company to see if it might be amenable to being acquired. The timing was perfect. Wallace Jones Jr., the third-generation owner, was ready to

retire and had just begun the process of selling. Only one other bidder was in the picture, and Jones gave Watts the last look.

Adding James Jones to the Watts family helped augment the Watts product line in water distribution. Moreover, since James Jones’ business had been largely confined to California and Texas, there was plenty of room for expansion, in some

cases, through Watts sales agents.

Many plumbing and heating wholesalers carry underground brass, so the Jones line — which had a reputation in its own area comparable to the Watts reputation for quality plumbing and heating valves — was a perfect complement.



A pattern began to emerge when Watts acquired the James Jones Company in 1986. Watts Industries was delving into new markets — such as underground water pipeline valves in the case of James Jones — primarily through the acquisitions of other more specialized valve-producing companies.

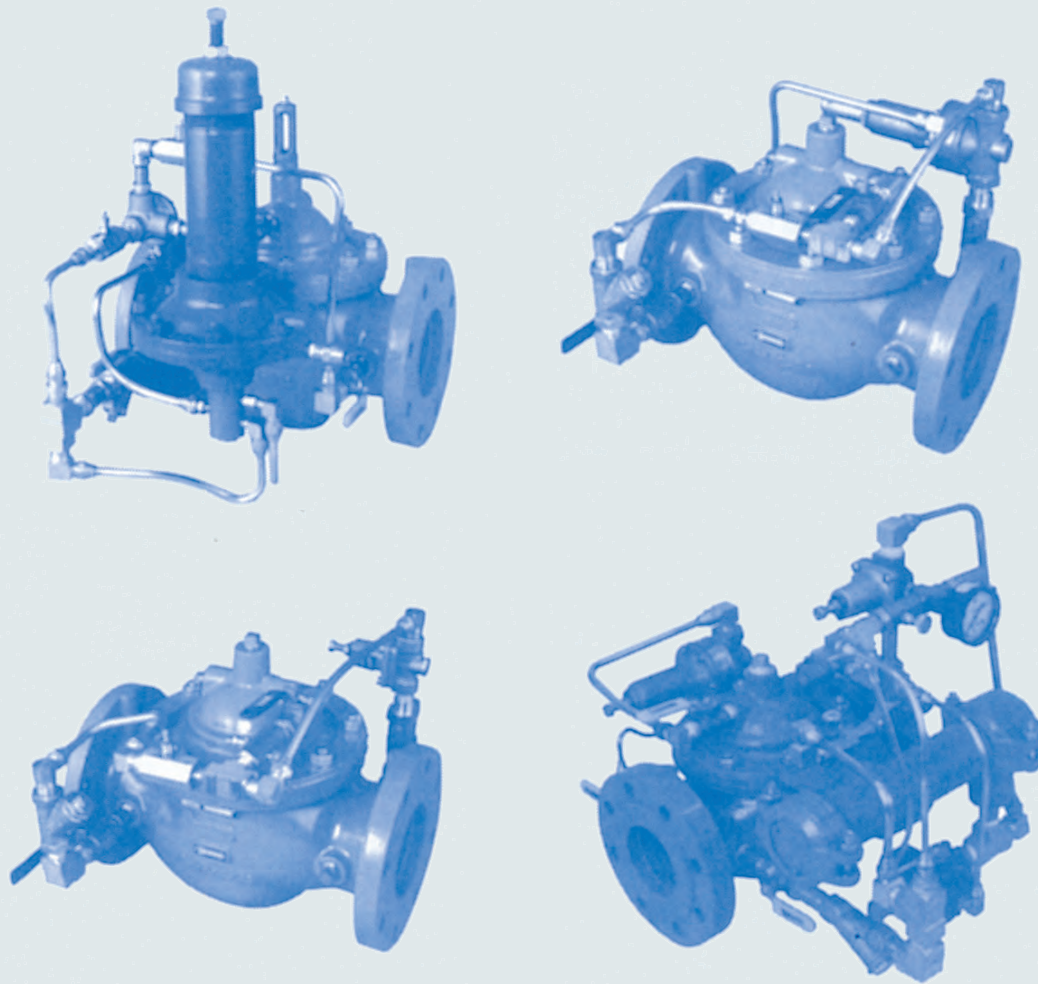

Watts ACV specialized in the design and production of automatic control valves, essential products in the waterworks industry.



A careful observer at the time might have seen a pattern emerging. Watts was diversifying into new markets but primarily through acquiring other valve companies. Watts was staying within the valve industry but broadening its core expertise to embrace specialized markets.

A small acquisition the following year furthered Watts' strategy of filling out its product line. Tim Horne had made overtures some years earlier to purchase Cla-Val, a competitor ever since Watts had entered the backflow-prevention field. Cla-Val's chief resource, as Tim Horne saw it, was its line of automatic control valves (ACVs), which are essential in the waterworks industry. Rebuffed by Cla-Val's owner, Horne changed strategies and purchased another ACV manufacturer, Muesco Valve. "It would have taken a month of Sundays to have developed such a product line," explained Tim Horne, "so we bought an also-ran in the industry who had the product line — not the name, but the product line. Today that's no longer called Muesco Valve. It's called Watts ACV. The trade name in this case didn't mean anything. We were buying the product."

At the same time, Watts had begun to broaden its horizons to Europe. Its first venture there was a company called Ocean BV. The founder was 82 years old and still running the company. He sold his check valves strictly to the market in Holland and was not making money.

Again, it was a perfect opportunity to expand a regional company to broader territory. As the only bidder, Watts paid \$3.2 million for Ocean BV in 1987. With an infusion of capital from Watts Industries, Ocean has grown in a decade to annual sales of about \$15 million and annual operating profits close to the original purchase price. It has also proved an important anchor for expanding into the entire European market.

In 1988, Watts continued the strategy of acquiring small niche companies, including another steam valve product line, that filled out the Watts product line and also made one major acquisition that would take the company into a new market. The large acquisition that year was KF Industries, which put Watts Industries into the oil and gas industry in a major way that Hale Oilfield had not. At the time, the oil and gas market was just beginning to emerge from a long slump, and KF had created a promising series of high-pressure ball valves. But the company lacked the financial resources to tool such a capital-intensive product line. Over the next five years, Watts invested an amount exceeding the purchase price of KF in plant expansions and machinery. At the same time, Watts also expanded the KF sales base internationally. The expansion investments worked: KF Industries' annual sales now exceed \$65 million. Acquiring KF paid off especially well in 1992, when Watts landed a major contract in Kuwait to supply valves for reconstruction of the oil industry infrastructure after the Gulf War.



Watts found the perfect opportunity to expand to the European market: Ocean BV, a regional check-valve manufacturer in Holland that was not operating profitably, was purchased in 1987 and has expanded to a \$15-million-a-year company.



The 1989 acquisition of Eagle Valve, with its specialized product line of check valves, broadened Watts Industries' production of specialized oil and gas products.

Opposite: The strategic approach of acquiring small niche companies was successful for Watts Industries. The purchase of KF Industries (Bill Niemann, president of KF, is pictured here with one of the company's products) enabled Watts to broaden its scope in the oil and gas market.



Because of its ever-increasing cash base, Watts was able to purchase Leslie Controls, a major supplier of high-technology steam valves to the U.S. Navy.



Circle Seal Controls introduced Watts Industries to the aerospace industry.



Highly sophisticated motor-operated valves are some of the innovative and specialized products manufactured at Circle Seal Controls.

The following year, 1989, Watts acquired two small companies: Nicholson Steam Trap — with sales of \$7 million a year — and Eagle Valve, which made check valves for oil and gas, thereby complementing the ball valve products manufactured by KF Industries. It also diversified the steam line dramatically by acquiring Leslie Controls, a major supplier of valves to the U.S. Navy and, to a lesser extent, to the industrial market. Leslie approached Watts, perhaps because Watts was becoming more interested in the steam market, and Leslie's high-technology steam valves would be a logical acquisition. Leslie had a \$33 million annual sales base, but with a price of \$18 million in cash (and the assumption of \$10 million in debt), it was a large operation to swallow. But Watts Industries was in an increasingly strong cash position, with its own annual sales now topping \$200 million.

The acquisition of Circle Seal Controls in 1990 gave Watts another company in industrial valves — but one that specialized in the aerospace industry. Modern jet aircraft typically contain piping systems for hydraulic oil and for air and water — all controlled by valves manufactured for these specific critical services. Within two years, Circle Seal had landed a prestigious contract to supply sophisticated motor-operated valves to Boeing for all aircraft except the 777.

Opposite: Timothy Horne and Charles Grigg are pictured here with a 72" manually operated Triton XR70 AWWA butterfly valve, manufactured by the Henry Pratt Company and used for water treatment service.





Pratt developed an extensive product line of valves used in municipal water distribution, water treatment and wastewater processing.



In Europe, Watts needed to expand in the plumbing and heating market. In 1992, the acquisition of IntermeS, S.p.A. in Italy afforded Watts Industries that opportunity.

At the end of September 1991, Tim Horne was finally able to realize his plan of total water management capabilities for Watts Industries by acquiring the Henry Pratt Company. Founded in 1901, Pratt had developed an extensive line of valves used in municipal water distribution, water treatment and wastewater. The timing of bringing Henry Pratt into the Watts fold was significant. National water quality standards had been established by the Clean Water Act of 1974 and the amendments of 1981 and 1984. Communities nationwide were and still are working toward compliance with the law through improved drinking water and wastewater treatment — fields in which Pratt valves are preeminent. “We’re by far the most significant valve company engaged in total water management — source, treatment, distribution, and wastewater,” said Tim Horne. “We don’t have a competitor with comparable breadth in water.”

Having established a position as the only valve company involved in all aspects of water management in the U.S., Watts was seeking to establish comparable status in Europe. One of the smaller acquisitions in 1991 had been Robinetterie SFR, a French maker of safety-relief valves and water-pressure regulators. Between SFR and Ocean, Watts had a foothold in Europe, but what the company needed was an established major plumbing and heating valve company — a European counterpart to the preexpansion Watts Regulator. In 1992, Tim Horne found it in Italy: IntermeS, S.p.A.

Even though the reconstruction of Eastern Europe offered rich opportunities, IntermeS had expanded too quickly too soon and had borrowed heavily. IntermeS

was also competing with Watts to establish a plumbing and heating distribution network throughout Europe. Tim Horne saw an opportunity. “We preempted other suitors,” he explained. “The people at IntermeS felt that Watts was the only company to enable them to carry forward. They knew we had the money to finance expansion and that the Watts name is becoming better known in some countries where we were both establishing distribution.” It was a large deal — more than \$40 million, including the assumption of IntermeS’ debt incurred by expansion.

Many of the acquired companies resembled Watts Regulator in the 1950s — strong products, a niche market and not enough cash to expand. Some resembled Watts in another way — by having a strong entrepreneur at the helm who valued the company higher than Watts was willing to pay. In these situations, Tim Horne typically gave an incentive to the entrepreneur to prove the company’s value, offering to pay a premium if the company performed well over the ensuing years with the entrepreneur staying on to run it. “That squelches the argument about the company being worth more than we’re offering,” he explained. “It also makes them more dedicated to the task of staying on and doing an aggressive job so they can hit the target and get the money. And it works.” Making such an offer gave Watts an edge over other bidders.

“The only reason any seller is willing to work under that scenario is that they feel Watts Industries has the track record to bring an improvement in operating results that they couldn’t enjoy themselves.” Tim Horne said. “Sellers also understand that most other buyers would not agree to such a buyout, or wouldn’t have the expertise to make it happen.”

Ultimately, retaining an entrepreneur to run an acquired company is a transitional phase. Historically, Watts was a family-owned business under the direction of one Horne at a time — Burchard, George or Tim. But grouping companies by areas of expertise streamlines management. For example, at Watts, one manager handles all the waterworks companies, another all the major steam companies, etc. “Rather than have staff executives who never get the facts and worry about the wrong information, we

rely on these hands-on managers,” said Tim Horne. “We tell them to go out and find their own acquisitions. We have them on the factory floor where they can find out what’s going on and report any problems.”

Staying with hands-on management has meant keeping the growth of central administration of Watts Industries to a minimum. “I think many companies get into trouble because they allow the staff to grow as fast as the company,” said

Tim Horne. “People forget how much sales you have to generate to support a salaried person. Our objective in Watts Industries as a whole is \$150,000 in sales per employee. And we’re right on that target.”

Watts’ acquisition strategy has been profitable from the outset. Prior to acquiring Intermeas, Watts had paid out \$160 million in cash and had assumed \$28 million in debt for all its acquisitions. In 1992, the acquired companies accounted for sales of \$240 million.

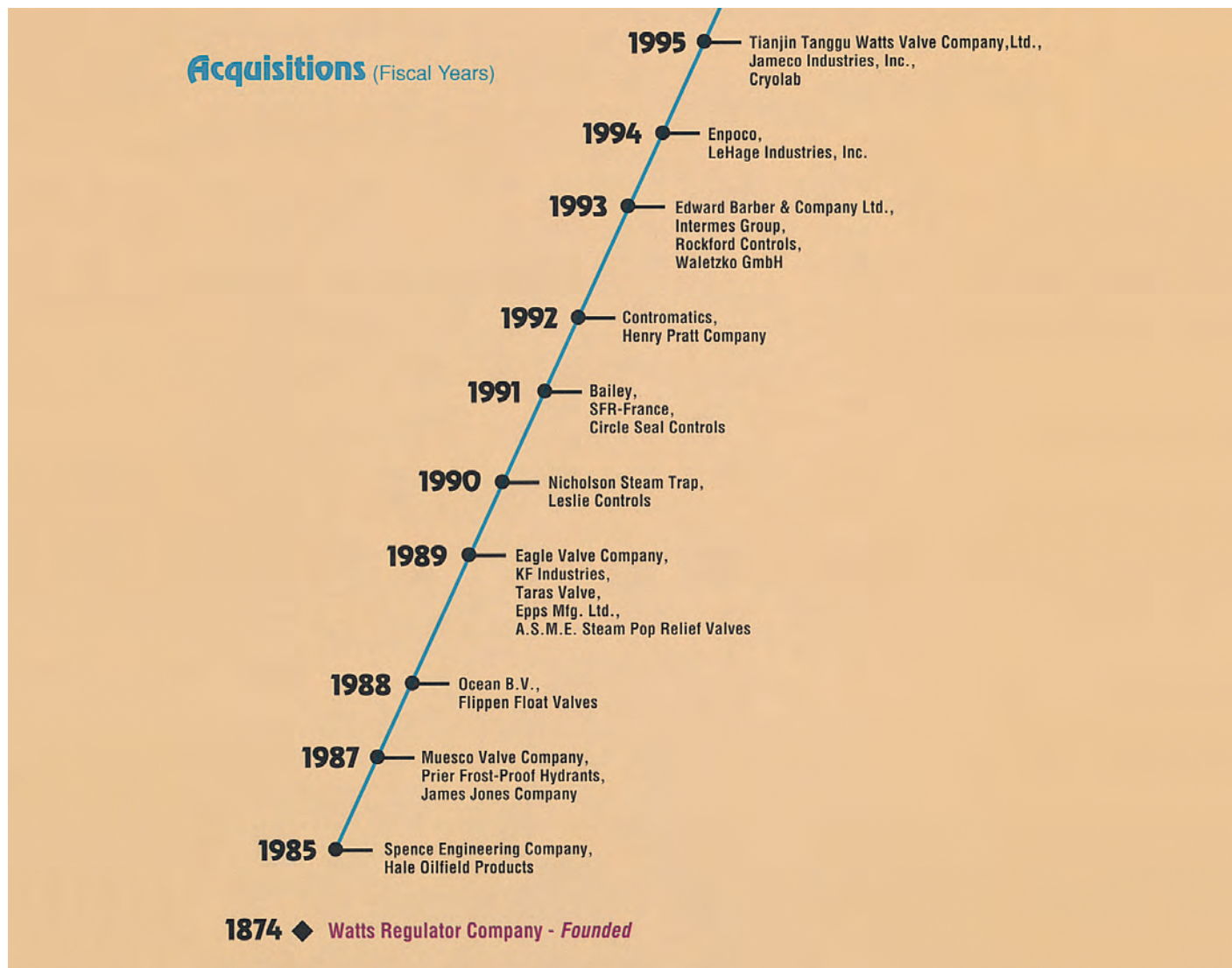

Inclusive of the companies mentioned in the text, Watts Industries has made 28 acquisitions since fiscal year 1985.



CHAPTER EIGHT

BUILDING A BILLION- DOLLAR COMPANY

Watts industries continued to grow despite the relative maturity of its U.S. markets and the worldwide economic downturn of the 1990s. Several acquisitions added to that growth. As a result, Tim Horne saw the company at another crossroads on its march from a half-billion to a billion dollars in annual sales. “I thought it was a reasonable goal that roughly a third of our sales would be represented by business outside the United States and Canada,” he said. “To do that, we had to be willing to do more acquisitions abroad and to engage in joint-ventures in countries and markets where outright acquisitions might not have been feasible.”

For example, as the 1993 fiscal year ended, Watts Industries acquired Edward Barber (UK) Limited and its wholly owned subsidiary, Edward Barber & Company, Limited (EBCO). Headquartered in Tottenham, England, EBCO manufactured and sold valves, meter boxes and accessories to the municipal water market. At the time of acquisition, its most recent one-year sales were approximately \$11.5 million. Founded in 1908, EBCO also maintained a nonferrous foundry.

The rationale for acquiring EBCO was straightforward. It was a major player in supplying products to the water utilities in Great Britain. As part of the privatization of U.K. water companies, the utilities pledged to spend more than £30 billion over the next decade to upgrade their water service infrastructure. Equally important, the U.K. was the only significant European Economic Community country where Watts Europe had little presence. EBCO provided a long-established and highly regarded U.K. manufacturing and sales infrastructure. Moreover, it provided a base to help establish a U.K. market for backflow-prevention products and for other water valve products manufactured by Watts Europe in the Netherlands, France, Italy and Spain. Explained Tim Horne, “This was our first acquisition to substantially address the overseas water utility market. It was a strategic choice to buy in because a handful of companies dominate the business.”

WATTS INDUSTRIES, INC.
5-YEAR PROJECTION OF GROWTH TO \$1 BILLION
(Dollar Amounts in Millions)



Compounded Growth Rate Per Year - 15%



The purchase of the English manufacturing firm, Edward Barber & Company, Ltd. (EBCO), was the first acquisition for Watts to substantially address the European water utility market.

WATTS INDUSTRIES, INC. FISCAL 1994 EUROPEAN SALES PERCENTAGES BY COUNTRY

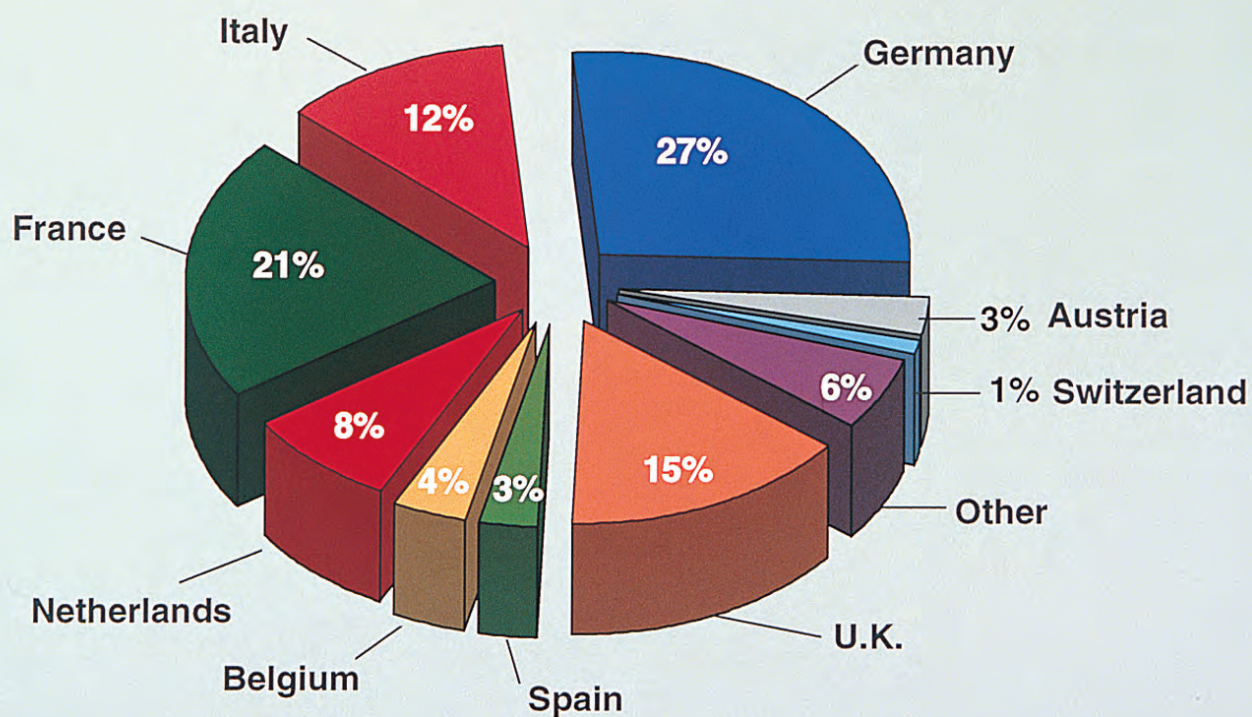

Watts Industries is now positioned to sell in all major Western European markets. With three successful acquisitions during fiscal year 1993, combined with previously owned companies, total annualized European sales are approximately \$80 million.

Tim Horne targeted Europe, and parts of Asia, as the most likely areas for future acquisitions. Watts Industries also intended to emphasize sales in Asia and Eastern Europe as a key strategy in developing overseas markets that would produce a third of overall sales. For example, because KF Industries was a leader in oil and gas valves, Watts

anticipated doing extensive business in Russia once that country's currency stabilized. The plumbing and heating valve business was already becoming established in the expanding economies of Poland, Hungary and the Czech Republic, largely through the acquisition of Intermed.



EBCO provided a foothold for Watts in the U.K., establishing a foundation to market backflow preventers and other water valve products.

DISTANT SHORES



The economies of the emerging world created another dramatic opportunity for Watts to expand. Asia presented a growth opportunity perhaps unparalleled in this century.

At the time, projections were that the gross domestic product (GDP) of the Asia-Pacific region would exceed that of the North American Free Trade Agreement (NAFTA) and the European Community (EC) by the end of the century. The region was poised to have the largest manufacturing economy in the world by the year 2015 if it continued the economic growth it achieved in the 1980s. China's GDP, for example, was 50% greater than Japan's. With such economic opportunity, China passed Japan as the largest destination of foreign investment. Mammoth construction projects for power generation, waterworks, sewage, petroleum and natural gas extraction, to name a few, presented growing markets for valves. Consequently, Watts management expanded its global focus to include China. The Chinese valve industry was fragmented, with many small companies; however, fewer than two-dozen valve companies accounted for the majority of output. Watts concentrated its efforts on forging joint-venture relationships with several of

these manufacturers who addressed the variety of market interests suited to the corporation's expertise.

On September 1, 1994, Watts announced controlling shareholder investment in a joint venture with the Tanggu Valve Factory located in Tianjin, east of Beijing. Tianjin was a city of 9.3 million people with a developing industrial culture. Tanggu was a valve company that was emerging at a time when China was concerned about the lack of domestic valve suppliers to support its infrastructure development projects. Tanggu's market orientation to waterworks and its extensive line of butterfly valve products provided a base for Watts to introduce modern manufacturing techniques and technical design advantages utilized at its Henry Pratt Division, headquartered in Aurora, Illinois. Tanggu had already been awarded the quality status of International Organization for Standardization (ISO) 9001 certification. Its future growth objectives were supported by an improving base of machine tool equipment, and the company utilized modern computer-aided design (CAD) for product development. As Tanggu's partner, Watts invested badly needed capital and transferred important valve technology to accelerate Tanggu's growth.

The movement to non-U.S. markets paralleled an exploration of other niche valve markets within North America — a direction, that Horne pointed out, was consistent with the reason Joseph E. Watts began the company in 1874: to fill the steam-control valve niche. Valves for the refrigeration and air-conditioning industries were a specialty market of interest to Watts. And if refrigeration, why not valves for cryogenics, Horne suggested. “Whenever you have pressure,” he smiled, “you need a valve.”

Horne had targeted fiscal 1995 as a year to expand internal research and development within all the Watts companies. This shift of emphasis was funded, in part, by redeploying some capital from manufacturing into research and development. Thus, Watts was focusing on internal growth through new product development as well as external growth through acquisitions.

KF Industries was the Watts Industries’ leader in product development, turning out a new product on average every 1.37 weeks. Horne said, “The key is communicating so well that they can do everything simultaneously — design, tooling, vendor selection, the whole manufacturing plan.” KF’s product development was customer driven. The company would take an order for a valve and start work on it. The most complex valve to date had taken only 11 weeks from order to shipping. “Even at the design stage,” explained Horne, “KF has its favored suppliers sitting at the table — people who will work weekends and extra shifts to get the prototypes out, to get the production tooling established. It radically accelerates what is normally a very slow process.”



Watts used state-of-the art CAD technology in its design and development stages.

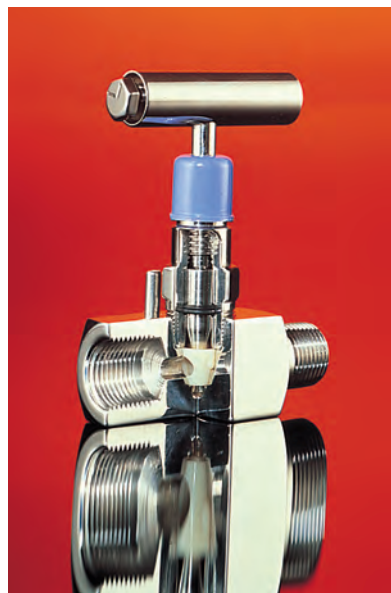

KF Industries represented a Watts ideal of remaining at the forefront of product development with innovative design and manufacturing capabilities.

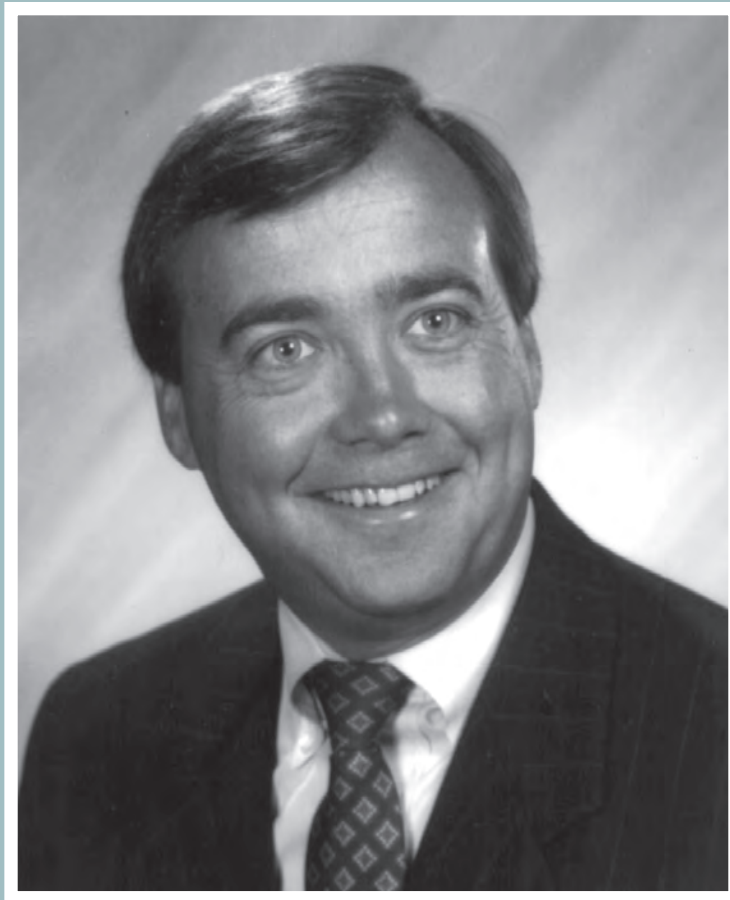

In keeping with the Watts standard of hands-on management, Timothy Horne hired **David Bloss** as executive vice president in 1993. Bloss had risen from the ranks of manufacturing to management in much the same fashion as Tim Horne himself.



Tim Horne admired this kind of take-charge, can-do entrepreneurship at the divisional level within Watts Industries. Watts had evolved into a company that ran best on directive rather than consensus management, he said. “Directive management is still participative,” he explained, “but you listen and then you must decide, keeping in mind that the majority is not always right. Our in-house experience is that directive management works for us because it keeps the companies nimble.”

At the same time, Horne added new management skills to the central management core of Watts Industries, thereby upgrading the skills of the com-

pany. In fiscal 1993, Watts added its first corporate counsel because the growing company faced ever more complex legal issues. It also added a risk manager to the payroll to handle various risk insurances and benefit insurances.

Perhaps most significantly, as fiscal year 1993 closed, Watts Industries completed its search for an executive vice president who could be groomed as Tim Horne’s eventual successor as CEO. David Bloss, who had headed Norton Super-Abrasives and before that had handled acquisitions and divestitures at Cooper Industries, was named to the post. “It’s a vote of confidence in continuing our hands-on management style,” said Horne, noting

that Bloss had risen from the ranks of manufacturing to management.

“We expect the company to continue with a very small corporate management structure, with a great deal of authority being delegated to the heads of individual companies,” Horne said. “It’s essential to stay in touch with the nuts and bolts of the business as it occurs every day, and that’s a skill Mr. Bloss most definitely has. We’re preserving a style — letting the entrepreneurial spirit bloom in the individual companies and keeping the lines of communication open.”

That is the Watts Way.



CHAPTER NINE

FAST-FORWARDING TO THE NEW MILLENNIUM: 1994-1999

In 1994, while achieving yet another record year for both sales and earnings, Watts acquired two Canadian-based manufacturers of water traps and drains, Enpoco and Ancon (now Watts Drainage Products). Their combined product lines enabled Watts to offer a total product offering, from the rooftop to the basement, to our North American commercial, industrial and institutional customers.

While reviewing Watts' development efforts in the Far East, Bob McLaurin, recently retired corporate vice president, Asia Operations, recalled Tim Horne's conversation that precipitated Watts' move into China. According to Bob, Tim said, "There's a whole section of the world out there that's coming to life. Why aren't we looking at Asia?" Bob noted that, "Watts looked at the whole area — Indonesia, Malaysia, Hong Kong, and ended up in China. Things were changing in China. Deng Xiao Ping, then the Premier of China, had decided to open things up economically, and we did a survey of the valve businesses that were there. We found a company in Tianjin, a state owned company that made excellent butterfly valves. So it looked like an ideal thing to get a foothold in China, and to be able to provide products back to Watts, all with a profit for that particular part of the market."

Thus, Watts launched its first joint venture in 1994 with the Tianjin Tanggu Valve Plant of the People's Republic of China, buying 60% controlling interest. An established ISO 9001 certified manufacturer, Tanggu sold its butterfly, globe and check valves to 29 provinces and autonomous regions in China and exports to the U.S., Europe, Australia and Southeast Asia. This set the stage for other commitments in China during the coming years to take advantage of this large emerging market and its low-cost manufacturing capability.

In Europe, sales were flat due to an ongoing recession but were offset by the rebuilding of East Germany and the developing markets of Poland, the Czech Republic and other emerging Eastern European markets. Despite this stagnation, Watts' consolidation of its acquired companies and product lines increased its operating profit while it continued to exploit opportunities for growth through acquisition.

Opposite: The Cazzaniga Company located outside of Milan, Italy, was acquired by Watts in 1999. It manufactures a variety of radiator valves, zone valves and manifolds that are sold throughout Europe and the U.S.



Tianjin Tanggu Watts Valve Company was Watts' first joint venture in the People's Republic of China, setting the stage for further business and manufacturing developments in ensuing years.



Attractive finished plumbing products manufactured by Jameco (now Watts Brass and Tubular) for the wholesale and do-it-yourself (DIY) retail plumbing and heating markets.



Watts' acquisition of Trubert SA (Watts Eurotherm) in Chartres, France, a manufacturer of hot-water safety mixing valves, reinforced its strategy of providing products that promoted the safety of water.

Then in July of 1994, Watts acquired Jameco Industries, located in Wyandanch, New York, a domestic manufacturer of valves and plumbing hardware sold through wholesale plumbing and heating distribution and to the burgeoning do-it-yourself (DIY) market. Representing one of the largest acquisitions to date, Jameco (now called Watts Brass & Tubular, Inc.) provided a complementary fit with Watts Regulator's Plumbing and Heating Division to offer one of the largest arrays of plumbing products in the U.S. Within a year, the somewhat antiquated Jameco operations were moved to Watts' more state-of-the-art and spacious manufacturing plant in Spindale, North Carolina, for greater manufacturing efficiencies.

Soon thereafter, Watts acquired the Anderson-Barrows Company, a Palmdale, California, high-volume manufacturer of hose connectors and brass fittings. The acquisition of both companies represented Watts' initial thrust and wholehearted commitment to the fast-growing, retail-oriented DIY market. Both acquisitions proved fortuitous in the growth of Watts' presence in this double-digit growth arena over the next decade.

Around the same time, while refining its program of developing synergistic acquisitions, Watts decided to divest itself of three waterworks-related companies: the Edward Barber & Company Ltd. in the U.K.; the Henry Pratt Company of Aurora, Illinois; and the James Jones Company of El Monte, California, to Tyco Industries. Watts had found that the

waterworks world was quite a different business whose sales representatives had little or no interest in backflow preventers, pressure regulators or automatic control valves. For example, Henry Pratt representatives were project specifications oriented, focused on getting large butterfly valves (up to 100" and greater) and other waterworks products specified into the project's principal package. Likewise, these divestitures foretold Watts' developing greater focus on providing products for the comfort, conservation, control, safety and quality of water used in residential, commercial and institutional settings.

To further reinforce this strategy, Watts acquired Établissements Trubert SA (Watts Eurotherm) in Chartres, France, in 1996. Trubert had some 50% market share in France and manufactured sophisticated valves using both wax-filled and bimetallic elements for residential and commercial applications. The strategy was to augment Watts' current mixing valve products, crossing over to the U.S. market to provide a broader offering of valves for scald protection in the home and in commercial and institutional settings.

Also in 1996, Watts made its initial venture into the radiant underfloor heating market when it purchased Artec G.m.b.H. of Besigheim, Germany. Artec (now part of Watts Industries Deutschland) distributed cross-linked polyethylene tubing (PEX) used as the flexible conduit for the hot water pumped under the floor in radiant heating systems in northern Europe.



Bob McLaurin, retired corporate vice president, Asia operations, spearheaded Watts' move into China in 1994.



Luigi Cazzaniga, president of Watts Cazzaniga, felt that Watts' acquisition of the company provided it with greater visibility and opportunity for its products in the rest of Europe, the U.K. and the U.S.



The large, highly automated Anderson-Barrows plant in Palmdale, California, produces high volumes of hose connectors and brass fittings for the retail-oriented DIY market.



With the acquisition of the Ames Company of Woodland, California, Watts ensured its dominance in the backflow-prevention field by establishing itself firmly in the domestic fire-protection market and by securing advanced and low-cost stainless steel fabrication technology.

With an eye to expanding its backflow-prevention business into the domestic fire-protection market, Watts acquired the Ames Co. of Woodland, California, in 1997. Because of its advanced and low-cost stainless steel fabrication technology used in manufacturing backflow preventers, Ames had 85% share of this niche market. In addition to protecting Watts' overall backflow market share, the Ames acquisition provided Watts with the distinct advantage of ensuring that Watts would maintain its technology leadership in the backflow field.

Meanwhile in Europe, Tim Horne brought to fruition his decades-long objective of acquiring a major manufacturer of heating products in Italy, The Cazzaniga Company. This venerable, family-owned and family-run manufacturer located just outside of Milan had 80% of its sales of radiator valves zone valves, and manifolds within Italy. According to its president, Luigi Cazzaniga, "We had

other firms looking at our company over the years like Honeywell and IMI, but I preferred to sell to Tim because for many years he had said, 'Luigi, your company is a real dynamo of production. Watts has some other companies in Europe that aren't quite so dynamic. Why not make a merger so we are both strong?' And in '99, Tim finally convinced me and the sale occurred."

The timing was right. Luigi Cazzaniga wanted to expand his company's reach beyond the Italian borders to address the global market that had evolved. Tim had known Luigi for more than 25 years and had broached the subject of a merger many times over the years while Cazzaniga had represented Watts in Europe from 1975 through 1985, selling a variety of Watts products in Italy, and Watts had sold some of Cazzaniga's products in the U.S. Thus, with this common history and experience in mind, Luigi Cazzaniga decided that his firm should join the Watts

Industries family to ensure its long-term prospects. According to Luigi, "The acquisition by Watts has provided us with more visibility in the world, more volume for the company. We are now more aggressive in the market with more selling points through other Watts companies in Europe, the U.K., and the U.S., and the acquisition has provided Watts with a well established, broad product line to address these large heating markets."

This success was due to the breadth of product offerings provided. According to Luigi, "The customers like the products and the service, particularly the complete line of products. Why? Because a customer prefers to buy everything, if it is possible, from one source — less invoicing, less delay, quicker service. All of these things give a company with a big product line a large opportunity and a dominant position."



AYASHKAYA-1
HAKURYU-5

MECATRA

H
12

CHAPTER TEN SPINNING OFF THE INDUSTRIAL, OIL & GAS BUSINESSES: 1999

Part of the strategy of buying so many different valve companies was stimulated by Tim Horne's concern in the early 1980s when the company was negatively impacted by significant downturns in the economy. For example, in 1981 because of inflationary problems in the U.S., the prime interest rate went up to 21%. As a result, all types of construction, including residential and commercial, were severely curtailed, negatively affecting the sales of many Watts products.

So, as noted earlier, Watts made its first acquisition in 1984 of Spence Engineering of Walden, New York, a company that specialized primarily in municipal, commercial and industrial heating products. Tim's goal was to create some industrial diversification so that Watts would not be totally reliant on construction. While Watts Regulator had always had a strong replacement market to carry it through tough times, its reliance on the residential and commercial construction market was hurting it. Thus, Tim's philosophy at the time was to start looking at the huge industrial market as a balance to Watts' dependence on the residential plumbing and heating market.

This strategy of acquiring industrial firms was quite successful. It brought into the Watts family companies that specialized in aerospace, petrochemicals, chemical processing and steam applications that were used by the commercial and industrial markets, and even the U.S. Navy,

in the case of Leslie Controls located in Tampa, Florida. In fact, the success in acquiring industrially oriented companies provided sufficient mass that it created some "tug of war" in allocating resources and management focus between the diverse industrial and plumbing and heating markets.

At that point, Tim Horne thought, "We've been so successful with our industrial acquisitions program that we almost have two separate businesses. How do we focus and do justice to each while they're both growing quite rapidly?" In addition, the sales volume of the industrial companies combined provided enough momentum to consider having a separate publicly traded corporation. Further, Watts' management felt that the multiplicity of the companies in its portfolio was confusing the investor public. "What are you anyway? You're in water, plumbing and heating, aerospace, oil and gas. How does it all work together?"

Thus, in October 1999, to add better focus for both sectors and to unlock greater value for Watts' shareholders as well as to spread their risk, it was decided to spin off the industrial sector companies under a different entity called CIRCOR, headed by David Bloss, former president and COO of Watts Industries. This spinoff was the prelude to the transformation of Watts Industries to Watts Water Technologies, Inc., returning Watts to its heritage in water with its focus on safety, comfort, conservation, control and quality.

Opposite: Watts' acquisitions of industrial and oil and gas valve companies reduced its dependence on the residential plumbing and heating market.

Watts Industries, Inc.



**1999 Annual Report
on Form 10-K**



David Bloss, former president and chief operating officer of Watts Industries, was tapped to head up CIRCOR, the spinoff of the industrial sector companies that helped to refocus Watts' emphasis on water-related technologies and products.

WATT'S
MTB



CHAPTER ELEVEN BACK TO THE FUTURE AS A BILLION- DOLLAR COMPANY: 2000-2004

With the advent of the year 2000, Watts began its renewed focus on water-related technologies by acquiring Heatway Incorporated in Springfield, Missouri. Now called Watts Radiant, it is a leading manufacturer of radiant underfloor heating systems in the U.S.

Mike Fifer, former corporate vice president and president of North American Operations who spearheaded the Heatway acquisition, indicated, “At the time, part of the strategy of the company was to emphasize product development with a focus on water with regard to comfort, safety, conservation, quality and control. Heatway addressed several of those categories, plus it had an exceptional creative management team that had a phenomenal reputation in the industry. Another facet they offered was that the basic product that they sold was an engineered system. Hence, Heatway was doing systems integration sales, rather than component sales. This dovetailed with Watts management’s long-term vision that someday we might be able to achieve higher margins or defend our margins better by selling packages of our products as systems, rather than as individual components.”

According to Doug White, group vice president, Watts Water Technologies, Inc., the acquisition of Heatway “let us broaden our involvement in the hydronic heating market, an historically important market for Watts products, and

specifically into the radiant underfloor heating systems. In addition, the acquisition of Heatway gave us a brand new product line of an electrical heating mat for undertile installations. These electrical mats were initially sold through tile distributors to tile companies across the country and to one division of Home Depot, but are now being sold to Lowe’s stores and other Home Depot outlets as well. This was one more entree into the retail market.”

“The other feature acquiring Heatway gave us,” continued White, “was a lot of expertise in how hydronic systems work, radiant or any other hydronic systems. And because you have to route this hot water through piping or tubing, Watts Radiant uses rubber type piping or crosslinked polyethylene (PEX) tubing. Watts Radiant’s knowledge and expertise in PEX has grown such that it now sells PEX piping to the plumbing industry that it currently imports from Watts Londa in Italy and buys from domestic third parties. But Radiant will soon begin producing its own PEX domestically in a new 140,000-square-foot plant that will eventually have the capacity to produce some 45 million linear feet of pipe a year to satisfy the booming demand for PEX used in radiant underfloor heating systems and for potable water use as well. In addition, this focus on PEX has led us to seek sources of PEX compatible fittings and other complementary products to help complete the systems approach.”

Opposite: Fimet’s Bulgarian plant located outside of Plovdiv, Bulgaria, provides Watts with an efficient assembly operation for its line of gauges.



Mike Fifer, former corporate vice president and president of North American Operations, saw the acquisition of Heatway, now Watts Radiant, as a way to get into integrated systems sales for higher margins rather than just selling low-margin parts and components.



Doug White, group vice president, noted that Watts' acquisition of Heatway also provided it with a brand-new product line of electrical heating mats for undertile installations, giving Watts an additional entree into the retail market.

On the retail front, Watts formed its Consumer Markets Division on January 1, 2000, to take advantage of the potential synergies of its earlier acquisitions. As noted by Jeff Polofsky, executive vice president of Retail Sales and Marketing, “At that time, we formed the Consumer Markets Division, charged with taking retail products, not only from Anderson-Barrows, but also from other Watts divisions and companies, providing a cohesive effort to sell as many Watts products as possible to the retail marketplace. Until that January, our efforts were segregated and somewhat disjointed. There wasn’t any Watts brand recognition and there was very little connectivity between Anderson-Barrows and Jameco back to mother Watts. The whole purpose of the formation of the Consumer Markets Division was to produce that connectivity of brand back to Watts, and to use existing relationships wherever they were, to expand the potential, and fully exploit all of the potential of all the brands.” Watts’ retail strategy is virtually unchanged from that time and has performed handsomely, posting a compound annual growth rate of 25% over the last decade.

In 2001, Watts intensified its acquisitions pace by buying four more companies, two in Europe and two in the U.S. To offer accessory gauges and controls in Europe and the U.S., Watts acquired Fimet S.r.L. located in Milan, Italy, with additional production facilities in Bulgaria. Fimet is a recognized leader in the manufacture of pressure and temperature gauges for use in the heating, ventilating and

air-conditioning (HVAC) markets in Europe. Watts also acquired Dumser Metallbau G.m.b.H of Landau, Germany, manufacturers of manifolds and boiler control packages for underfloor heating systems. Dumser’s products are key components in providing pump-group package solutions to the major European boiler manufacturers and the European underfloor heating OEM market. These components have now spread to the U.S. through Watts’ domestic OEM division. This focus on heating and the OEM market in Europe is the result of the efforts of Dennis Cawte, group managing director, Watts Industries Europe, and of Johan van Kouterik, chief financial officer (CFO) and vice president, Watts Industries Europe; and their staff to cross-link and consolidate operations of the disparate companies that then made up Watts Industries Europe.

Dennis Cawte recalled, “When I joined Watts in October 2001, it was really eight manufacturing companies focused on their own markets — no sharing of distribution, limited synergies from intercompany trading, or from sharing development work. To capitalize on these opportunities, Johan and I put into place a pan-European strategy addressing several fronts: 1) set up pan-European working groups made of sales and marketing, research and development, manufacturing, sourcing, and logistics personnel; 2) designate specific plants to have design and control responsibility for specific products; 3) make local sales management responsible for all Watts products sold in their region.”



Watts Radiant’s expertise in hydronics and the use of PBX tubing has led the company to make a major investment in a new 140,000-square-foot plant for the manufacture of PBX for radiant underfloor heating and for potable water use.





The common exhibition style shown here at a U.K. show is but one example of the effort to standardize the public face of Watts to establish a single brand in Europe.



A few examples of the broad range of hot-water safety mixing valves manufactured by Powers Process Controls, Inc., acquired by Watts to expand its offerings to the residential, commercial and institutional markets.

The application of Watts' pan-European strategy was extremely important according to Johan van Kouterik because, "On the sales and marketing side we like to cover all of Europe, and we want to benefit further from the new countries joining the European Union on May 1, 2004. Then additional countries will join in 2007, and our aim is to focus and further increase our presence in Eastern Europe with our huge portfolio of products. We have not one competitor with as wide a range of products to offer to the wholesale and OEM markets. With our recent acquisition of Dumser, we can move strongly into the OEM business, with big boiler manufacturers like Bousch Buderes of Germany. OEM sales currently account for more than 50% of our total business."

One of the key tactics of this strategy was the push to create a single Watts brand. Dennis Cawte noted, "We have started to create a brand to reinforce our pan-European focus. Whereas before we had Watts Cazzaniga, Watts Ocean, Watts Dumser, etc., known only in their own countries — now we're Watts Industries Europe. We have one common face to the market, with a common literature look, one common exhibition style, standardizing everything to create a single brand in Europe. It's now starting to pay dividends?" Johan van Kouterik continued. "This very aggressive corporate identity program, with one house style, one logo, promoting Watts Industries at the European exhibitions has had a very positive effect with the larger buying groups and wholesalers who are

now seeing us as a pan-European player in the market. Watts' brand recognition is taking place."

Meanwhile in the U.S., Watts acquired two major companies in 2001 to further its transformation to a water technologies company. Powers Process Controls Inc. of Skokie, Illinois, is a leading manufacturer of hot-water safety mixing valves used in residential, commercial and institutional applications. The acquisition of Powers added greater depth in the technical know-how of designing and manufacturing valves that accurately blend hot and cold water to prevent scalding in the home, schools, hospitals and commercial buildings.

Further pushing the technology envelope, Tim Horne decided to purchase Premier Water Systems of Phoenix, Arizona, a manufacturer of reverse osmosis (RO) water-purification systems. Although little was known about RO within Watts at the time, Tim's vision of Watts as a water technology company encompassed this esoteric technology for purifying water and saw it as a stepping stone toward other water purification and treatment means. Three of the main issues forming Tim's vision were that: 1) population growth is driving the demand for water, for example, the demand for potable water has doubled since 1950 and is now believed to be growing at three times the population growth; 2) the supply of fresh potable water is fixed, i.e., less than 1% of the earth's surface water is fresh and available for consumption; and 3) requirements for water conservation are rapidly increasing.



The Consumer Markets Division under **Jeff Polofsky**, executive vice president of Retail Sales and Marketing, was formed to create a comprehensive effort at marketing all of Watts' products into the retail channel and to establish the Watts brand with end users.



The implementation of a pan-European strategy by **Dennis Cawte**, group managing director, Europe, and by **Johan van Kouterik** (next page) helped create a single Watts brand in all of the countries.



According to **Johan van Kouterik**, chief financial officer and vice president, Watts Industries Europe, the application of a pan-European strategy in sales and marketing provided Watts with greater reach within the European Union (EU) to offer its broad portfolio of products.



Paul Lacourciere noted that Watts entered into its second joint venture with TWT by starting up a bronze foundry in Tianjin as part of its vertical integration strategy in China.

Putting a unique spin on water conservation, Premier offers a patented, Zero Waste (ZRO-4) undersink RO drinking-water system for the home. Other conventional RO systems waste between four and 20 gallons of water to produce just one gallon of drinking water. The ZRO-4, however, reintroduces the drain water back into the household's hot-water loop, thus wasting no water. With today's ever-growing concerns for water conservation, imagine the water savings to a municipality, not to mention the water savings to the homeowner.

According to Doug White, group vice president, Watts Water Technologies, Inc., "Premier was purchased to give us a foothold in the water treatment industry, a rapidly growing industry that is going to be much more rapidly growing. Although Premier is primarily a retail product line, selling to all of the big box retailers and producing about 75,000 RO units per year, our big goal is to broaden into other marketplaces, such as the commercial arena. Partially driving this move is the Safe Drinking Water Act of 1996, scheduled to take effect in 2006, that mandates new lower arsenic levels in drinking water. This legislation requiring a dramatic reduction in arsenic levels permissible in drinking water will allow point-of-use systems, such as Premier's RO systems, to be used by water utilities that have unacceptably high arsenic levels in their water and that cannot afford to put in large centralized treatment systems."



The acquisition of Premier Water Systems ushered Watts into the RO technology for purifying water.



Premier Water Systems' patented ZRO-4 under-sink RO purification system for drinking water in the home conserves water by reintroducing the drain water back into the household's hot-water loop, unlike conventional RO systems that send the drain water to waste.



Watts opened its new state-of-the-art 125,000-square-foot Tianjin Watts Valve Company plant in the fall of 2003 to machine the castings from the Tianjin Watts Bronze Foundry. The Tianjin Watts Bronze Foundry, with a capacity to produce more than 200 tons of finished castings per month, was an outgrowth of Tim Horne's vision.

Activities in China were also heating up. Paul Lacourciere, vice president of manufacturing, Watts Water Technologies, Inc., noted, "In 2001, we broke ground on a second joint venture, opening up a bronze foundry with our partners from Tianjin Tangu Watts Valve Company (TWT). This foundry, known as Tianjin Watts Bronze Foundry (TWB) has the capacity to do over 200 tons per month of finished castings."

This new foundry was also Tim Horne's brainchild recalled Bob McLaurin. "Tim had said that 'Our business is bronze.' He had been saying for years that foundries in the United States were going to be negatively impacted by many cost elements, environmental controls, etc., and that we ought to be looking

around China for bronze foundries. We did and couldn't find anything that was compatible with us at the time. So, since we had a joint venture in Tianjin with TWT and we knew the people and the operation, we decided to create a second joint venture with them to be sure we had a bronze capability to meet potential market demand." Subsequently in 2004, because the bronze operation was such a critical piece of Watts' manufacturing strategy, Watts bought out the remaining 40% of this foundry from its TWT joint-venture partners to create a wholly owned foreign enterprise (WOFE).

In 2002, the steady acquisitions pace continued, including acquisitions in China as well as in Europe and the U.S. In its continuing search for low-cost man-

ufacturing capabilities in China, Watts found a stainless steel braided connector manufacturer in Taizhou City in southern China's Yuhuan region that was making some of the same products as our Anderson-Barrows plant in Palmdale, California. Paul Lacourciere related "After evaluating and testing considerable samples of its products, we entered into a joint venture with the Chen Guan Metal Hose Factory by acquiring 60% of the company. Knowing we had both a low cost producer and one of the few foreign companies with all of the U.S. code approvals for its products, we broke ground for a 250,000 sq. ft. addition."



Watts' Taizhou Shida Pipe Product Manufacturing Co., Ltd., formerly called Chen Guan Metal Hose Factory.



ADEV's (now Watts Electronics) manufacturing plant in Monastir, Tunisia, provides Watts with cost-effective production of HVAC electronic heating-control thermostats.



Representative grouping of Watts Electronics' thermostatic controls that complement the offerings of Watts GRC, Spain.



Foerster & Rothmann's pneumatic gauge product line provides further depth to Watts' previously acquired Fimet gauge product offerings to the OEM market.

European acquisitions of ADEV Electronic, with manufacturing plants in Rosieres, France, and Monastir, Tunisia, together with its largest distributor, Prominent AB, Gothenburg, Sweden, in 2002 allowed Watts Industries to strengthen its position in the HVAC electronic controls market. ADEV (now Watts Electronics) specializes in the design and manufacturing of electronic heating-control thermostats that complemented the mechanical and electronic controls of Watts GRC, Spain. Prominent AB, ADEV's exclusive distributor in Scandinavia, provided Watts with its first, fully owned subsidiary in the Nordic region that comprises Sweden, Denmark, Norway and Finland. Prominent (now Watts Nordic) became responsible for marketing the complete range of Watts products into this very important heating market.

Emphasized Dennis Cawte, "Our business in Europe is different than that of the U.S. in that 60% of it is heating. Before, Watts Industries Europe was in radiator-type heating controls, and radiator manual thermostatic controls, but now we've moved on into underfloor heating components and packages. This has become a very important part of our business, as we focus on supporting the major German and Spanish boiler manufacturers with pump groups. Today we are the leading European manufacturer of pump groups and of underfloor heating manifolds. Our acquisitions strategy is designed to increase the package solution offerings to the major OEM's in the underfloor

heating market. We are focused on supplying the total solution package: electronic thermostats, manifolds, electro-thermic actuators, flow meters, gauges, and balancing valves. As a result, last year our OEM business was 50%, whilst our wholesale business was 42%, a major shift from wholesale to OEM."

Watts' acquisition of F&R Foerster & Rothmann G.m.b.H., Neuenburg am Rhein, South Germany, a manufacturer of pneumatic gauges for the OEM market, added even greater depth to the gauge product line provided by the earlier Fimet acquisition. By consolidating both product ranges, Watts formed the Watts Instrumentation Division as a specialized group focusing on the gauge market for both OEM and wholesale distribution markets worldwide.

To remain competitive on the global stage, Johan van Kouterik noted, "On the manufacturing side we have to look at cost reduction — the design of our products; the use of less expensive material, say changing from metal to plastic; our labor costs. For that reason alone we have our plants in Monastir, Tunisia and Plovdiv, Bulgaria. We are fairly pleased with the progress of these two operations. Both have good workforces and are quite efficient, with labor cost at about 1.40/hr, equaling that of China. So, we are moving more production into these areas of cheaper labor in order to control our margins, while maintaining quality and short lead times."

Amplifying on the results of this strategy, Dennis Cawte indicated, “Our two low cost manufacturing centers in Tunisia and Bulgaria give us a cost advantage, when you consider the freight and agents costs, plus the minimum inventory requirements involved with going to China. Acquiring ADEV, now called Watts Electronics, allowed us to transfer production from Spain to Tunisia and update our historic range of thermostats allowing us to regain market share, and at the same time improve our profitability. We also moved the assembly and casting machining of our Safety Unit, which was also under serious price pressure and loss of market share. We redesigned the product in our French plant with components from our Italian and Dutch plants, and assembled it in Tunisia. This allowed us to launch a competitive Safety Unit, resulting with an increase in market share and profitability.”

Back in the U.S., Watts continued its quest of maintaining its position as the foremost backflow-prevention device manufacturer in the world by acquiring Hunter Innovations, Sacramento, California, in 2002. Doug Powell, vice president of R&D Engineering at Hunter and formerly at Ames Company in nearby Woodland, California, was responsible for the revolutionary metalworking techniques applied to stainless steel pipe and flow-control mechanisms developed at both companies. At Ames, the basic manufacturing technology was that of bending or forming stainless sheet into a valve shape to accept the flow control and monitoring devices; at Hunter, stainless pipe is made perfectly round, and then laser technology is used to cut the metal away to provide the opening for the parts that go inside of the valve.

In applying new technology to backflow devices, according to Doug Powell, “We try to push the design standards envelope. Our group does a good job of determining what contractors and end users need. So we push our design parameters to the limit for our customers, but still fall within current performance standards. In general, we are focused on making lighter, smaller, and simpler backflow products.”

In August 2002, Watts announced the appointment of a new CEO, Patrick S. O’Keefe, to succeed Timothy P. Horne, who retired as chairman of the board, CEO and president after 43 years of unstinting and loyal service to the company. Tim’s visionary leadership, career and contributions are documented in the foregoing pages, as is his ability to inspire those around him. In the words of his daughter, Tara Horne, “My father dedicated his passion and life’s work to the evolution and market leadership of Watts Regulator, both domestically and globally. During his tenure, Tim was responsible for a vast array of accomplishments, too numerous to outline here — which brought his team at Watts from a successful family-owned business to a publicly traded company with an international presence in the global valve market. Under his tutelage, Watts Regulator grew into Watts Industries with an aggressive, successful acquisition strategy that continues to this day.” Tim Horne retired as an employee of Watts on December 21, 2002, but remains as a consultant to the company and a director.



Hunter Innovations uses advanced laser-etching technology to cut passages in stainless steel piping that will accept the backflow-prevention components.



Doug Powell’s group at Hunter Innovations pushes the design standards to create lighter, smaller and simpler backflow devices.

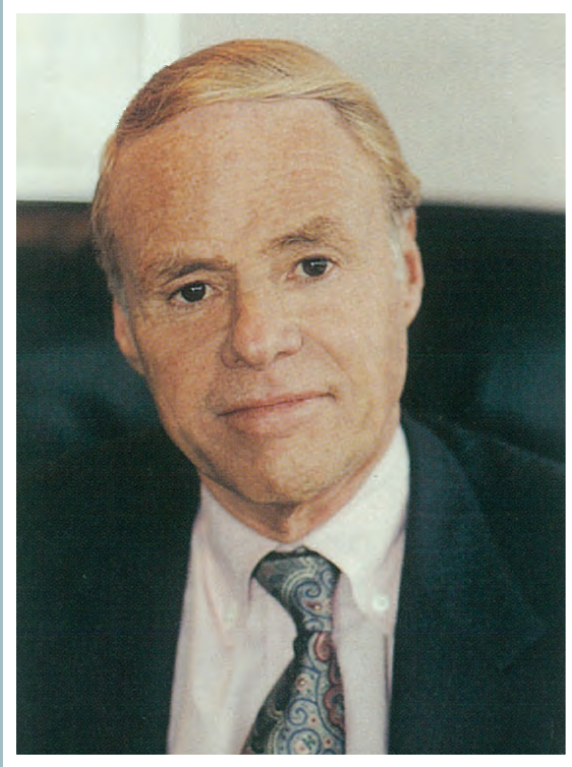

Timothy P. Horne, retired chairman of the board, CEO and president.



Patrick S. O'Keefe, president and CEO of Watts Water Technologies, Inc.

Patrick S. O’Keefe brought to Watts more than 20 years of domestic and international experience in executive-level positions with Mark Controls Corporation, Amtrol, Inc., Crane Co. and National Service Industries. Just before joining Watts, Pat was the president, CEO and director of Industrial Distribution Group, a publicly traded company. In furthering the direction set by Tim Horne, Pat stated, “Our vision is to make Watts the company of choice for our associates, customers, and shareholders. To do this, we must be leaders — encouraging our associates to achieve their full potential, exceeding customer expectations, and generate top-tier returns. We will achieve this vision by setting goals which, though beyond our immediate reach, are achievable; by pursuing them with energy, creativity, and decisiveness; by growing profitability through effective sales management, new product development, and selective acquisitions; and by continually striving to deliver extraordinary results.”

In October 2003, Watts Industries changed its name to Watts Water Technologies, Inc. Commenting on this major shift, Pat O’Keefe noted, “The Watts Water Technologies name more accurately reflects our strategic focus on providing solutions to our customers’ water-based needs. We believe that water equipment suppliers have an opportunity to achieve above-average growth characteristics due to the increasing pressure that consumers are facing to assure the safe use of high quality water. In this respect, Watts Water Technologies is well positioned to respond to these growing needs.”

Elaborating further, Pat stated, “The name change to Watts Water Technologies embodies our commitment to using

leading edge technology to produce products that will provide our customers with the highest level of water quality, safety, control, conservation, and comfort.”

On the financial front, in May 2003, Watts had strengthened its position by retiring some earlier high-percentage debt vehicles in exchange for lower-percentage senior notes, providing it with net proceeds for use in general corporate purposes. Then, in December of 2003, Watts Water Technologies, Inc. made a public offering of 4,600,000 shares of newly issued Class A common stock, whose net proceeds would be used to fund potential acquisitions and for general corporate purposes.

During 2003, Watts Industries Europe continued filling its acquisitions portfolio to address the OEM and heating markets by acquiring Martin Orgee UK Ltd. located in Kidderminster, West Midlands, U.K., and Guiliani Anello, S.r.L., located in Cento, near Bologna, Italy. Martin Orgee distributes a line of plumbing and heating products to the wholesale, commercial and OEM markets in the U.K. and Southern Ireland. It also assembles pumping groups for underfloor radiant heating systems, further solidifying Watts’ position as a leading supplier to the heating market in the U.K. With gas being the primary fuel in Europe for domestic and commercial heating, Watts Europe expanded its existing fuel and gas product range with the acquisition of Guiliani Anello. Well regarded for its high-quality products for the gas and fuel markets, Guiliani Anello, manufactures a full range of products for the OEM burner market, including solenoid valves, regulators and filters.

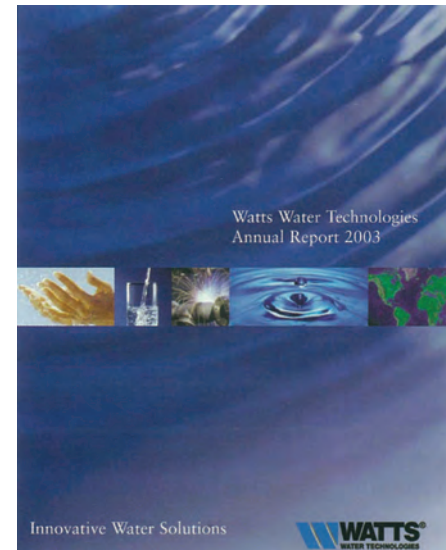



In March of 2004, Watts acquired the remaining 40% equity interest in what is now called the Taizhou Shida Pipe Product Manufacturing Co., Ltd. (“Shida”) that had been held by its former joint-venture partner. Now a WOFE, Shida provides Watts Water Technologies with a low-cost solution for manufacturing hoses, hose connectors, multilayer tubing and stainless steel braided hoses for all water-supply products used in both residential and commercial applications.

Looking to future developments in China, Paul Lacourciere stated, “Our strategy going forward is to be as vertically integrated as possible in both northern and southern China. We will continue to look for more ways to make product in our own factories and expand our sales force in China to take advantage of the huge growth and expansion that that country is going through.”



Watts Europe expanded its existing fuel and gas product line with the acquisition of Guiliani Anello, a well-respected manufacturer of high-quality solenoid valves, regulators and filters for the OEM burner market.

Tony Tala, general manager for Watts’ Asia Operations, stated, “Based on what has happened in the last two to three years, I see greater expansion of China manufacturing. I believe the operation in China will become more and more important as part of Watts’ strategy by providing low cost, high quality products, as well as helping in the distribution, packaging, and sourcing of products. Further, I believe that in the next few years, Watts will undergo a major transformation, with more and more manufacturing activities outsourced to places like China, Bulgaria, and Tunisia.”

Continuing in 2004, Watts Water Technologies, Inc. has further bolstered its position in the water technologies fields by acquiring Flowmatic Systems, Inc. of Dunnellon, Florida. Flowmatic's product line of high-quality water filtration and conditioning equipment complements that of Premier's RO line and brings the additional facet of a strong distribution channel of independent water purification and conditioning dealers.

Doug White observed, "While Premier is strong in the retail market and Flowmatic is well established through dealerships, we believe both companies will create a synergistic force by exchanging products and sales channels to increase their sales, while at the same time provide a strong basis for additional water purity related acquisitions. So the acquisition of Flowmatic gave us a strategic advantage of going into a whole new class of trade—the water dealers. Flowmatic is becoming a major customer of Premier, selling Premier products with the Flowmatic name. Their business is growing at double-digit rates every year and we expect it to continue. They're also doing a good job with customers interested in systems about the same size as Premier's commercial systems. Flowmatic also does a lot [of] business with components for the commercial industry, helping us build that sector."

In April 2004, Watts acquired TEAM Precision Pipe Work, Ltd., of Ammanford, West Wales, U.K. TEAM custom designs and manufactures manipulated pipe and

hose-tubing assemblies that are used in the HVAC markets. TEAM is a supplier to major original equipment manufacturers of air-conditioning systems and several of the major European automatic air-conditioning manufacturers. According to Patrick S. O'Keefe, CEO of Watts Water Technologies, Inc., "We believe the acquisition of TEAM Precision will strengthen our presence in the European OEM market. Our current OEM customer base in Europe includes major boiler and air conditioning manufacturers. The TEAM Precision technology allows us to expand our product offering to both of these important market segments. TEAM Precision also provides us with a state-of-the-art, low cost, manufacturing plant in the U.K."

Coincident with the new millennium, Bill McCartney became the new chief financial officer (CFO) of Watts Industries and helped complete the spinoff of CIRCOR in 1999. "Watts' revenues were then about \$475M and we began to refocus its efforts on water technology. So here we are five years later with approximately \$800M in revenue and the billion-dollar mark well within reach. Our overall financial objective is to grow our business by at least 10 to 12% per annum. We plan on doing that through a combination of acquisitions and internal growth. Historically, we have done this on a very balanced basis of about half and half acquired and internal growth. We feel that we can be a billion dollar company when we exit 2006."



Now a Watts WOFE, the Taizhou Shida plant provides Watts with a low-cost source of high-quality hoses, hose connectors, multi-layer tubing and stainless steel braided hoses for the residential and commercial markets.



The acquisition of Flowmatic Systems, Inc. further increases Watts' strength in the water technologies field with the addition of its high-quality water filtration and conditioning product lines to complement Premier's RO line.



TEAM Precision Pipe Work, Ltd., acquired by Watts Europe, provides manipulated pipe and hose-tubing assemblies to major OEMs of air-conditioning systems and automatic air-conditioning systems.

Bill continued, "Our strategies have been successful over the past 24 months, as we've increased sales and profits to record levels, while we've been able to get some multiple expansion and get recognition as a water company from Wall Street. If you look at the macro environment in which the company is operating, the water markets are very favorable to us, and I think that will continue in the longer term, both in terms of people's awareness of water, because its cost is increasing and consumers' growing demand for pure water. As the general world economy improves, there will be an increasing demand for water, both for human consumption and manufacturing. Also, from a safety perspective, the demographics in North America of an aging population, in particular as the boomers age, favor our product offerings. There'll be more and more emphasis on safety and comfort related products, such as our hot water safety mixing valves and radiant heating systems. So we have an excellent strategic positioning of our products for future growth."

Lynn McVay, executive vice president of Wholesale Sales, North America, looked at Watts' future through a market dynamics prism. "I see Watts as an IBM, a Coca Cola, it has the staying power it needs to succeed. With the consolidation going on with manufacturers, and even with our customer base, you need a company like Watts that has the resources to purchase the companies that have products to round out its core product line, and so to make a package of products that is attractive to customers. Watts has done a good job in making the right acquisitions to add the right products."



Given the manufacturing developments during recent past years, **Tony Tala** believed the operations in China would become even more important in Watts' drive to provide low-cost, high-quality products to its customers worldwide.



Bill McCartney, Watts Water Technologies, Inc. CFO, believed Watts would reach sales of a billion dollars by the end of 2006, half through organic growth and half by continued acquisitions.



Lynn McVay, executive vice president, Wholesale Sales, North America.



Ernie Elliott, executive vice president, Marketing and Engineering.

Regarding Watts' evolution to a water technologies company, Lynn felt that our agents and customers had embraced the change very enthusiastically. "With customers now having a compelling story to hear, agents want to be part of relating that story. With its broader focus on water technologies, Watts has reinvented itself. No one can deny that there's a shortage of fresh water in the world, and Watts is well positioned with products it has been making for years, and now we have new water technologies we can offer through Premier and Flowmatic. Agents who know us very well have a good feeling about the shift. They are excited with the change."

Looking at future product developments to meet customer needs, Ernie Elliott, executive vice president of Marketing and Engineering, offered the following insights: "One of the major areas that we are focusing both R&D and marketing efforts on is thermostatic mixing valves. We believe this is a major growth opportunity for the company as national safety codes are being formulated to control both thermal shock and outlet water temperature at plumbing fixtures. Through Watts and Powers in the U.S.A. and Watts Eurotherm in Europe, the company has a very good technology base upon which we are building and expanding."

"Another area we are seriously exploring is water damage prevention. Water damage and the resultant direct cost of repair, the potential of mold development, its attendant abatement costs and litigation—all are creating a potential significant market opportunity. Materials technology is another area that is impacting plumbing systems. Plastic piping such as cross-linked polyvinyl chloride (CPVC) and cross-linked polyethylene (PEX) for potable water distribution has become accepted in our markets, and the company has decided to manufacture PEX piping and valve accessories that are used with both PEX and CPVC piping."

"Areas we are researching on the marketing side include products for residential fire protection, safety and comfort products for an aging population, and enhanced grease removal systems for commercial applications. Watts will continue to look for specialized niche products or markets to serve that have the potential to generate above average sales and profits. Providing specialty products that enhance the health, safety, and comfort of customers has proven an extremely successful formula for the company, and we look forward to identifying, developing, and meeting the changing needs of our markets in the coming years."



Thermostatic hot-water safety mixing valves provided Watts with a major growth opportunity because national safety codes were being created to control thermal shock and outlet water temperatures at plumbing fixtures.

Comfort QUALITY *conservation* SAFETY CONTROL

As this decade in Watts' history marched quickly forward and as Watts approached the significant billion-dollar milestone in sales, Pat O'Keefe, from his fresh perspective as the sixth CEO of Watts in its 130-year history, recapped, "The Watts name change serves as a reflection and a proof of the technology and manufacturing innovations that it is pursuing in Asia, Africa, Europe, and the United States. The name change came at an interesting inflection point. Watts recognized it had to change its paradigm in order to continue growing and to serve its customers. Although Watts had done well in the DIY market for the last ten years, its passion for growth refocused efforts on the retail market and on other areas of the business. The strategy was formulated to: 1) go back to the commercial market, away from industrial; and 2) to focus on new areas of growth in the core business, i.e., water safety, conservation, quality, control, and comfort. For example, as piping systems in homes are changing into all PEX, for both potable and non-potable applications, Watts is adapting its products to PEX in anticipation of the wholesale adoption of PEX in the U.S. as it is in

Europe because it is so easy to install and maintain. Our recent investment in Watts Radiant's PEX manufacturing plant reinforces our intent to be a major player as the U.S. converts over to PEX and to radiant underfloor heating systems using PEX. This is a good example of Watts' innovative nature, of its ability to change to take advantage of the shift in the market. Another example is our quick adoption of Hunter products that served as a wake up call to our older cast iron backflow products. By acquiring Hunter, we bought innovation rather than try to develop it in house.

Further reinforcing this approach was our May, 2004 acquisition of Orion Fittings of Kansas City, Kansas. Orion is an industry leader in providing the engineer, the contractor, and ultimately the end user with drainage and pure water piping products of unsurpassed quality. Orion's total capability in the design and manufacture of engineered polymers such as polyethylene and polyvinylidene fluoride (PVDF) into acid waste, pure water, and neutralization systems make all acid waste and high-purity and process piping systems available from one manufacturer. Innovation can come from multiple sources."

In summarizing Watts' future directions, Pat O'Keefe projected, "Since our founding in 1874 as Watts Regulator Company, we have grown into a global manufacturer of safety and flow control products for the residential and commercial plumbing and heating and water quality markets. Our diverse product offering ranges from simple under-sink water shutoffs to residential and commercial water filtration units to complex turf warming systems used in professional sports stadiums."

Continued Pat, "In 2004 and beyond, we plan to continue our focus on five strategic water applications: quality, safety, control, conservation, and comfort. We believe that these applications provide our customers with the products they desire and provide our shareholders with the growth opportunity they require. This macro driven strategy should carry us for 10 to 20 years, providing us with growth that exceeds the Gross Domestic Product by a factor of +3."

**This is a further evolution of
The Watts Way.**





CHAPTER TWELVE GROWING & SUSTAINING WATTS' GLOBAL LEADERSHIP: 2005-2013

From 2005 through 2007, Watts experienced record growth as the company generated strong financial results, driven largely by a series of key acquisitions and global market expansion. Net sales grew by double digits year over year in both 2005 and 2006, culminating in an historic milestone when the company crossed the \$1 billion sales threshold in 2006.

Watts continued its rapid growth trajectory in 2007, again growing double digits as the company completed the year with \$1.4 billion in sales. As a strong economy created favorable construction tailwinds, this growth preceded a softening that started taking hold in the latter half of 2007 and was the precursor to a major global recession.

“Watts’ exceptional growth during this period was driven by organic growth, as well as an aggressive string of strategic acquisitions, which would ultimately include 15 companies within three years,” said Tim MacPhee, treasurer and vice president of Investor Relations. Organic growth was driven by Watts’ leadership position in the U.S. wholesale market as well as increased demand in Europe for products that helped to promote the use of alternative energy sources.

In January 2005, Watts acquired HF scientific, Inc., a manufacturer of instrumentation equipment, test kits and chemical reagents used for monitoring water quality in a variety of applications. This acquisition provided Watts with a product line that presented significant global niche market opportunities.

A prime example of this is HF scientific’s instrumentation products that help monitor the treatment of ballast water in ocean transport ships. This treatment ensures that foreign microbes and bacteria aren’t introduced into local harbors. Ballast water is carried in container ships’ ballast tanks to improve stability, balance and trim. Ballast water is typically taken up or discharged in different harbors when cargo is unloaded or loaded. While the acquisition of HF scientific happened more than 14 years ago, the move continues to pay off today.

Opposite: An employee prepares Socla pipeline strainers for finish work in Virey le Grand, France.



A Mueller Steam Specialty wye strainer milling machine.

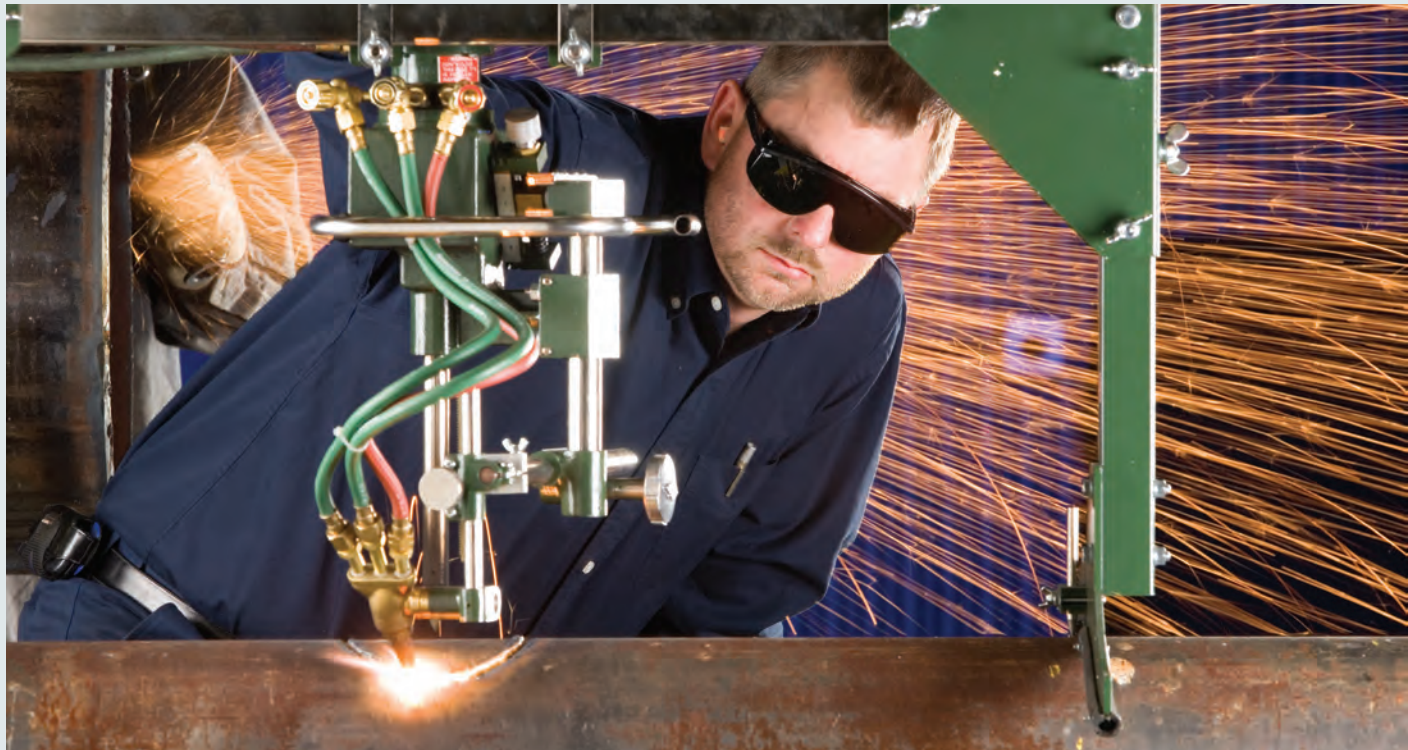

A Mueller Steam Specialty pipe-hole-cutting operation in St. Pauls, North Carolina.



A Dormont blue hose gas-connector installation in a commercial kitchen.

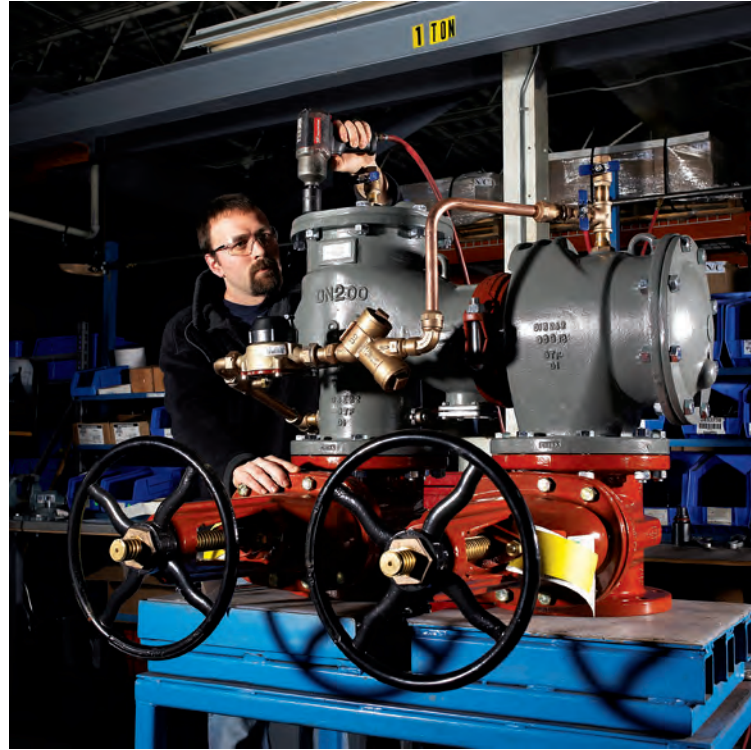

FEBCO large-diameter backflow preventer final assembly in Franklin, New Hampshire.

According to Nick Ganzon, vice president, Global Electronics and Water Quality, “In 2019, the International Marine Organization (IMO) will begin enforcement of a new rule requiring all ocean going ships to treat their ballast water and make sure it is clean prior to discharge. HF scientific instruments play a critical role in this process through the monitoring of disinfection levels in ballast water and is seen as a leader in the global marketplace to help ship owners comply with this legislation.”

In December 2005, Watts acquired FEBCO, a manufacturer of backflow-prevention valves with a strong presence in residential and commercial landscape irrigation. According to Kenneth Lepage, general counsel and executive vice

president, “The FEBCO acquisition gave a significant boost to Watts’ backflow prevention platform. Watts had strong existing backflow offerings for plumbing and fire protection, and the addition of FEBCO’s irrigation backflow product line solidified Watts’ leadership position in the category.”

Mueller Steam Specialty, a leading full-line supplier of pipeline strainers and check valves, was also part of the FEBCO deal. Up until this point, Watts’ product offering of strainers had been focused on small-diameter strainers for plumbing applications. The inclusion of Mueller Steam Specialty allowed Watts to expand into the large-diameter commercial and industrial markets.

Looking to access the food-service industry, Watts acquired Dormont in December 2005. Dormont is a leading provider of American-made flexible stainless steel connectors for natural and liquid propane gas connections and a leader in commercial food-service applications in North America.

“This acquisition was largely about entering new markets, as it gave Watts a valuable foothold in commercial food service and allowed us to introduce our portfolio of water filtration and drainage solutions like grease interceptors into this space,” said Gregory Gyorda, director of Employee and Customer Training.



A Watts Dead Level® trench drain installation.

As the company grew through acquisitions, Watts maintained its focus on global expansion, opening additional sales offices in Eastern Europe as well as a new distribution center in Ningbo, China. “The ability to channel products through this distribution center, which was set up in a free-trade zone, combined with low-cost sourcing in China, enabled Watts to realize significant supply chain savings through reduced duties and 30 percent lower production costs,” noted MacPhee.

While the company was expanding, Watts continued to drive new product innovations to meet customer demands. In 2008, Watts introduced the Dead Level® Trench Drain, a trench-drain system featuring an original presloped

design and other new facets to enable efficient installations and long-term performance.

Another significant new product introduction was the Watts OneFlow® antiscaling system, an environmentally friendly solution for preventing scale buildup through a process known as template assisted crystallization (TAC). TAC enables minerals to be brought together to form microscopic crystals that can flow through a system without attaching to fixtures, pipes and appliance components. TAC has been found to be an effective salt-free scale-prevention technology.

In late 2007, Watts began to see declines in the North American residential

and commercial construction market and softening in many Western European construction markets. By 2008, the subprime mortgage crisis hit, crippling the U.S. economy and setting the stage for the most significant global recession since the Great Depression.

To weather this economic storm, Watts focused its efforts on optimizing the business by adopting lean manufacturing methodologies and introducing One Watts initiatives. Over the next couple of years, a series of consolidations, strategic acquisitions and further global expansion would help Watts access new revenue streams and markets to withstand the tumultuous macro environment.



A Watts OneFlow® antiscale system installation.

In 2010, Watts implemented initiatives focusing on continuous improvement and operational excellence. Watts launched its Continuous Improvement Operating System program, or CIOS, to equip employees with a standardized approach to continually improving business processes. CIOS was created to improve operational and financial results as well as to deliver improvements across key business metrics and enhance customer satisfaction.

In the following years, Watts employees continued to develop their skills and expand their use of the company's continuous improvement tools to drive improved performance across all key customer-focused operating metrics, including safety, quality, delivery, productivity and working capital.

During this time, Watts also introduced the concept of One Watts, a broad initiative focused on breaking down silos, sharing strengths and leveraging synergies across the company. The first step was to establish a centralized marketing communications (MarCom) team in North America, which Gyorda calls the first “great experiment” of One Watts.

“We had acquired companies that all worked independently of one another. We were just starting to realize the potential of working together in a unified approach and the efficiencies that could be gained as a result. There were several key leaders across the company at the time who were skeptical of shared services,

and it took some focus and effort to begin generating results that would start driving adoption,” noted Gyorda.

One Watts continued to gain momentum throughout the next nine years and was ultimately used in many capacities, including rebranding CIOS into what is now called the One Watts Performance System (OWPS).

A series of consolidations, product line rationalizations and strategic acquisitions also played a role in helping Watts better navigate these belt-tightening years. Additionally, Watts reduced its manufacturing plants and divested several noncore businesses.

In April 2008, Watts made its largest acquisition to date in buying Denmark-based BLÜCHER for \$170 million. BLÜCHER is a leading provider of stainless steel drainage systems in Europe and a worldwide leader in providing stainless steel drainage products to the marine industry.

“These products laid the groundwork for Watts’ global drains platform (launched in 2016), and have helped the company better penetrate the global food and beverage market, as well as the European drains market,” noted Ken Nolan, global technical director of Fluid Solutions.

During this period, Watts also acquired Socla in April 2011. Socla is a leading

manufacturer of a wide range of water-safety valves and flow-control solutions for the plumbing market and for the HVAC market.

“With products distributed worldwide for municipal, industrial, commercial and residential use, Socla was viewed as the Watts equivalent in France. The acquisition solidified Watts’ position as a leader in Europe,” said Nolan.

In January 2012, Watts acquired British Columbia-based tekmar Control Systems, a designer and manufacturer of energy-saving control solutions for HVAC applications, including a wide range of hydronic systems. tekmar currently forms part of a global electronics platform

(launched in 2015) within Watts that is focused on driving the company’s Smart and Connected strategy, which was introduced to the markets in early 2019.

These years were also marked by global expansion, as Watts extended its presence in Eastern Europe — specifically in Russia and Poland through the Socla acquisition. The company opened a sales office in Dubai, which enabled Watts to grow its business in the Middle East by more than 20% in 2011. Watts also established a sales office in Bangalore, India, for its BLÜCHER stainless steel drainage products.



Left: tekmar Control Systems in Vernon, BC, Canada. Right: Socla’s main plant in Virey le Grand, France.

Opposite: BLÜCHER stainless steel pipe fabrication in Vildbjerg, Denmark.





Company executives, local dignitaries and members of the local media attend the groundbreaking ceremony for Watts' new lead-free foundry in Franklin, New Hampshire.



Hundreds of Franklin employees wear blue "We Are Lead-Free" T-shirts to commemorate the groundbreaking.

Perhaps the most significant undertaking during this period was Watts' leadership in response to the Reduction of Lead in Drinking Water Act, introduced in January 2011. Under the terms of the law, by January 2014, all U.S. water systems providing water for human consumption needed to use materials, devices and components meeting the new "lead-free" requirement, defined as a weighted average of 0.25% lead calculated across the wetted surfaces of any pipe, pipe fitting, plumbing fitting or fixture.

The legislation had sweeping impact on the industry because bronze, which had been the industry standard, has naturally occurring levels of lead in it. As the industry grappled with how to address this situation, Watts made the courageous and visionary decision to open a dedicated lead-free foundry, allowing Watts to control its own destiny in the U.S. and position the company as a trusted source for lead-free products. Watts also took a leadership role in educating the industry about lead free as a founding member of the "Get the Lead Out" Consortium.

The lead-free foundry was a massive undertaking for Watts that involved a tremendous investment of time and resources. Not only did Watts need to construct the foundry, but it also had to reinvent thousands of products. On June 21, 2013, Watts officially opened the doors of its new, 30,000-square-foot, state-of-the art lead-free foundry in Franklin, New Hampshire.

"Building the lead-free foundry was truly a visionary decision — we were the only one in the industry with such a facility and it gave us direct control over the quality and safety of the products made there," said Director Emeritus Timothy Horne. Today, the majority of Watts products used to provide water for human consumption in the Americas continue to be made in this foundry.

Having the vision to make bold decisions — like the creation of the lead-free foundry — is one of the hallmarks of Watts' legacy as an iconic industry leader.

Finally, several leadership changes occurred between 2011-2014. CEO Pat O'Keefe, who had led the company since 2002, stepped down due to health reasons in January 2011. O'Keefe, along with CFO Bill McCartney, led the aggressive acquisition program discussed earlier. When O'Keefe retired, he handed the CEO reigns over to Watts' Chief Operating Officer David Coghlan. Coghlan served in this role for three years and largely focused his efforts on breaking down silos within the company, thus paving the way for One Watts.

In 2013, longtime CFO Bill McCartney retired. McCartney had worked in various financial roles for Watts from the time the company was \$100 million in sales and was the face of the company to Wall Street investors. Dean Freeman was hired to assume the CFO role in 2013. In January 2014, Freeman took over as interim CEO and president upon Coghlan's departure.



A foundry worker pours liquid bronze into molds.



Employees assemble various components in a manufacturing cell in Franklin.

WTS
LISTED
NYSE

WATTS[®]

WATER TECHNOLOGIES

WTS
LISTED
NYSE

Celebrating Over 140 Years of Innovation & 20 Years on the NYSE



WATTS[®]
WATER TECHNOLOGIES

WEDNESDAY
16
SEPTEMBER

WTS
LISTED
NYSE

CHAPTER THIRTEEN

TRANSFORMING WATTS FOR THE FUTURE: 2014-2019

In 2014, Watts appointed industry veteran, Bob Pagano, to the roles of CEO and president in a move that would ultimately shift the trajectory of the company. When Pagano joined the company, Watts gained a seasoned executive with more than 25 years in the flow-control space and a proven track record of growing businesses through strong customer focus, new product development and strategic acquisitions.

“As Watts emerged from the global recession, we were looking for an experienced leader who could re-energize the company and refocus on driving profitable growth,” said Tim Horne. “Bob had the exact skills, experience and leadership needed to move the company forward.”

Pagano’s first priority included a listening tour during which he met with Watts, leadership team, employees, customers and investors to identify needs, gaps and opportunities for the business. From there, Pagano moved quickly to develop a cohesive strategic plan that integrated a bottom-up and top-down approach focused on five key pillars: growth, operational excellence, commercial excellence, One Watts and a talent and performance culture. “It was critical from the outset to establish a clear plan and vision for the company to ensure that the entire organization was on the same page and focused on the same mission,” said Pagano.



Watts' Global Strategy.

Opposite: Members of Watts' executive leadership team gather to ring the closing bell on September 16, 2015, to celebrate the company's more than 140 years in business and 20 years listed on the New York Stock Exchange (NYSE).



Bob Pagano, CEO and president.



CEO Bob Pagano and other business leaders attend a ribbon-cutting ceremony in October 2016, marking the new location for the company's sales and distribution facility in Dubai and the opening of a new Watts® Works Learning Center.

Understanding that developing a complex global entity like Watts into a unified organization would take time, Pagano made several strategic hires, adding executives with specific areas of expertise who could quickly institute change. Key hires during this time included: Munish Nanda, president of the Americas and Europe; Todd Trapp, CFO; Nick Ganzon, vice president, Global Electronics and Water Quality; Chris Jamieson, senior vice president, Marketing and Business Development; Roberto Vengoechea, senior vice president, Fluid Solutions; and Andrew Windsor, senior vice president, Sales.

Under the leadership of Pagano and his executive team, Watts set out on a transformation journey to become a leaner, more customer-centric organization with a laser focus on growth. Watts began its transformation by reigniting

customer focus and commitment to commercial excellence.

“With the churn of executive leadership, the company had lost some of its focus on the customer,” noted Gyorda. “Among Bob’s first priorities was bringing the “voice of the customer (VOC)” into focus and tailoring our business around the customer needs,” added Munish Nanda.

The company established several VOC initiatives, including customer councils, so Watts could hear directly which challenges customers faced and how Watts could better address them through product solutions. “Through VOC initiatives, we were able to better understand the wants and needs of our customers and incorporate those insights into product development decisions,” said Pagano.

Watts also sharpened its focus on the residential and commercial markets, specifically setting up market verticals in high-opportunity subsegments in health-care and hospitality. “The company also made a greater effort to better engage its sales representative organizations, holding each more accountable,” noted Chris Jamieson.

Watts worked to further deepen customer relationships through the implementation of extensive customer training programs. In April 2016, Watts opened its world-class Watts® WorksSM Learning Center at the company’s headquarters in North Andover, Massachusetts, and subsequently opened or upgraded learning centers in multiple sites across the world, including Dubai, UAE; Biassono, Italy; Ningbo, China; Woodland, California; St. Neots, U.K.; and St. Pauls, North Carolina.



These centers provide customers, channel partners and Watts' employees with valuable knowledge and experience of Watts' products and system solutions.

"To complement the learning centers, Watts has developed a standardized, blended learning approach to customer training highlighted by the launch of a Learning Management System that makes online product 'e-learning' courses available to customers around the world 24/7. In 2018, Watts trained over 24,000 unique customers in person and online in North America alone and that number jumped to more than 61,000 in 2019," explained Gyorda.

Implementing and offering these training programs helped Watts strike the critical balance between being a highly successful global entity while still maintaining intimate, personalized and one-to-one customer relationships.

"Customer training initiatives have helped to revitalize our relationships with our customers," explained Andrew Windsor, senior vice president of Sales, Americas. "Not only are we able to establish deep personal relationships through in-person interactions, but we also gain highly valuable customer feedback that we can incorporate into our new product development efforts."



IntelliStation digital mixing valve training for controlling water temperatures.



Customers being trained on our Automatic Control Valves for controlling water pressures.

Opposite: An instructor delivers hands-on training to customers at the company's flagship Watts® Works Learning Center in North Andover, Massachusetts.



What is a Business Performance System?



It is a collection of tools, processes, and b... that keeps us ahead of the competi...

Another key area of transformation was evolving Watts into a leaner, more integrated organization. Through a series of operational excellence initiatives, Watts began implementing strategic restructuring initiatives aimed at eliminating redundancies and improving efficiencies while instituting footprint-reduction efforts to reduce the net operating footprint by 30% in the U.S.

Watts also focused on global-sourcing initiatives to reduce sourcing costs by leveraging economies of scale. These combined efforts resulted in millions of dollars of savings that could be funneled into new product-innovation investments. To drive deeper integration and further streamline operations, Watts also accelerated One Watts initiatives. These initiatives focused on a wide range of areas, including deeper integration among Watts' product platforms, establishing common sales systems, integrating culture and employee engagement and launching universal branding efforts.

“The disciplined commitment to One Watts initiatives effectively removed siloes that previously existed,” said Horne. “Today, our business units communicate up, down, left and right in order to identify and deliver on customers' needs for unified solutions.”



Employees gather in the continuous improvement meeting room in Franklin, New Hampshire.



Local leaders review the status of continuous improvement initiatives in Gardolo, Italy.

Opposite: Employees in Ningbo, China, learn about the OWPS.



Watts' heating and hot-water system solutions are on display at an industry trade show, featuring products from the AERCO, Powers, PVI and Watts brands.

Perhaps the most significant transformation during this period of Watts' history has been the evolution of the company from a components provider to a system-solutions provider. In 2014, after an exhaustive review of Watts' product portfolio, Pagano made the bold decision to exit certain noncore product lines with a combined revenue stream of \$175 million.

While a potentially risky move, this decision allowed Watts to move away from low-margin, undifferentiated products and progress further in its journey from being a components supplier to a complete solutions provider. "Walking away from that revenue stream was a courageous decision, that ultimately proved to be the right one," said Horne.

At the same time, Pagano set about adding key strategic acquisitions to the company's portfolio to bolster its system-solutions approach. In November 2014, Watts acquired AERCO, a New York state-based manufacturer of high-efficiency commercial condensing boilers and water heaters. Up to that point, Watts offered many of the components of a water-heating system but not the boilers or water heaters themselves. Commenting on the importance of the AERCO acquisition, Pagano quipped, "Watts had all the ornaments, now we finally have the Christmas tree."

In November 2016, Watts acquired PVI in Fort Worth, Texas, a leading manufacturer of high-efficiency commercial water heaters for new construction and building retrofits in North America. PVI

complemented the AERCO brand's leading position in high-efficiency boilers, thus strengthening Watts' ability to provide customers with complete heating and hot-water system solutions.

To further propel Watts' evolution to a system-solutions provider, the company began making significant investments in research and development (R&D). Based on customer demand, new product-innovation efforts focused on building electronics and internet connectivity into products.

"Watts' has a significant competitive advantage in this space because of our strong electronics capabilities, and now we are putting these capabilities to use to drive innovation," explained Nick Ganzon, vice president of Global Electronics and Water Quality.

New product innovations featuring “smart technology” have included IntelliStation, a smart mixing and recirculation system that enables facilities managers to remotely monitor and control water temperatures to provide hot water consistently and on demand, wherever and whenever it is needed. Additionally, it has the ability to run a hot loop at night to prevent legionella in that part of the system. Another innovation is the Watts Vision Smart Home System, an intelligent smart home system featuring integrated Wi-Fi and designed to control both hydronic and electric underfloor and radiator heating, lighting and other electrical appliances in the European market.

Under Pagano’s leadership, Watts continued expanding into new global markets. Watts has strategically targeted markets that offer growth opportunities, including New Zealand, Australia and the Middle East. In November 2015, Watts acquired New Zealand-based APEX® Valves, a specialist in the design and manufacture of control valves for low- and high-pressure hot-water and filtration systems. This acquisition gave Watts a bigger foothold in the New Zealand and Australia markets.

Watts also strengthened its presence in the Middle East, which represents another huge market opportunity — especially given the growing preference for U.S. and European codes and standards in the region. Watts also expects to expand further into Latin America, where Mexico, Colombia and Chile are all developing stronger water-quality codes to protect their populations, presenting significant market opportunities. Watts plans to significantly grow emerging markets over the next five years.



AERCO Benchmark Platinum® high-efficiency commercial condensing boilers.



Products from Apex® Valves are designed for the agricultural industry, such as water-supply valves in a typical farming operation.



Cleaning up the Merrimack River.



Donating food and supplies to the Lazarus House for families in need.



Outfitting a boy's soccer team in Gambia, Africa, with Watts-branded uniforms.

With Pagano at the helm, Watts bolstered its commitment to corporate social responsibility, including environmental sustainability, social stewardship and governance. In 2016, Watts launched a global partnership with the Planet Water Foundation, a U.S.-based nonprofit that helps bring clean drinking water to the world's most disadvantaged communities. Through this partnership, Watts has the power to help thousands of people obtain essential access to clean drinking water. As part of the partnership, Watts participates in Planet Water Foundation's "Project 24," where Planet Water and several prominent corporate partners span the globe to build 24 water towers in 24 hours to commemorate the United Nations' annual World Water Day. In 2017, in response to the devastation left by Hurricane Maria, Watts helped fund the installation of two water towers to help the people of Puerto Rico. A team of Watts employee volunteers traveled to Puerto Rico to build the water towers at two local schools.

"In an emotional moment, one student extended an arm into the running water and said, 'I can see the palm of my hand in the water!'" recalled Kathy Bradley, an executive assistant and project volunteer. "We taught them that the towers were not just for drinking, but for also producing water that can help keep our hands clean. It felt like we were really making a difference because we were building something. To not have access to clean water — you really take that for granted."

Watts was recognized for its commitment to sustainability in late 2019 when the company was named among "America's Most Responsible Companies" by Newsweek magazine.





Watts employees volunteer to build water filtration towers in Puerto Rico.



CONNECT. CONTROL. CONSERVE.SM

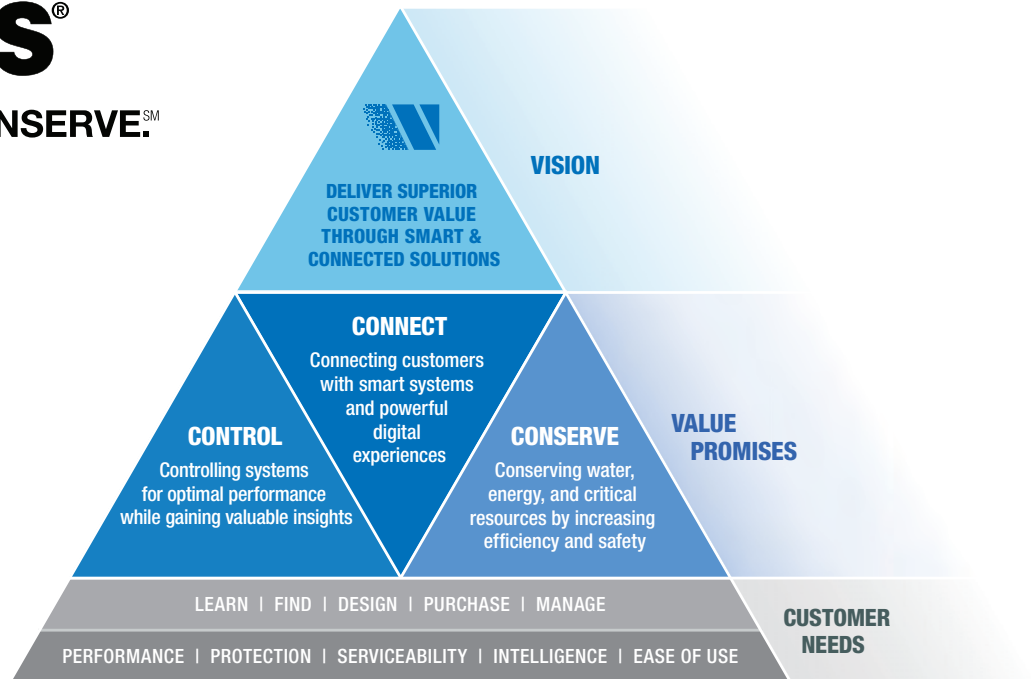

Watts' Smart and Connected strategy was announced to the investor community during the Q1 earnings call in May 2019.

Looking ahead, Watts is positioned for exciting continued growth and transformation. In early 2019, Watts unveiled its Smart and Connected strategy, which leverages Watts' deep electronics expertise to create connected products that will better meet the needs of customers. The Smart and Connected promise is "Connect, Control and Conserve," which embodies the three dimensions Watts aspires to deliver: connecting customers with smart systems, controlling systems for optimal performance and conserving critical resources by increasing efficiency and driving sustainability.

"The basis of our smart and connected strategy is driven by our customer needs," commented Pagano. "Our customers expect their products to provide higher levels of performance, intelligence and ease of use. Our Smart and Connected strategy positions us to meet these emerging needs and expectations."

Watts invested more than \$10 million in this initiative in 2018. In addition to the IntelliStation and Watts Vision Smart Home System, recent innovations include AERCO's onAERremote monitoring system, which enables easy and reliable remote monitoring of AERCO gas-fired boilers and water heaters; SentryPlus Alert and Flood Protection Technology, a new flood protection system that automatically detects potential flood conditions, shuts down water supply and issues multichannel alerts so users can take action; and Syncta Backflow Test Management, a cloud-based backflow-management application that dramatically simplifies and speeds backflow test reporting and submission.

By 2023, Pagano predicts at least 25% of all Watts products will be "electronified." Aligning with the refocus on the

customer, product managers are working with customers to determine what products and solutions need to be connected. "Our product managers have a strategy for electronification," said Pagano. "The products we have in the pipeline are going to truly change the industry."

As Watts marks its 145th anniversary, the company has become an example of an American manufacturing success story — evolving from humble beginnings to the position of a global industry leader, all while staying true to its core business and values. By understanding and addressing customer needs, staying at the forefront of innovation, constantly looking ahead and pushing the industry forward, Watts will continue to be an iconic leader in the industry for years to come.

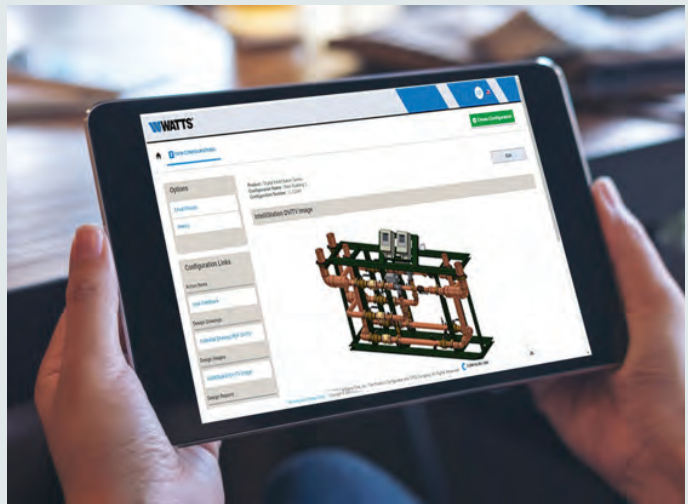

A sampling of Watts Smart and Connected products, which are driven by customer needs.



CHAPTER FOURTEEN WATTS PREPARES TO TURN 150: 2020-2023

Watts continued to advance key strategic initiatives to drive long-term profitable growth, achieving record sales and profitability despite the global disruptions caused by the COVID-19 pandemic.

“We remained focused on our customers’ needs in the face of very challenging and volatile business conditions,” said Bob Pagano, CEO. “Amid unprecedented supply chain disruptions, we leveraged our robust business processes and operating model to proactively meet growing customer demands and responded quickly to a myriad of complex global macroeconomic conditions, including significant inflationary headwinds and geopolitical uncertainties. Although our global teams were significantly impacted by the pandemic professionally and personally, they did an exemplary job remaining dedicated to taking care of our customers. I am extremely proud of all of them.”

In addition to continuing to invest in R&D, acquisitions, and product growth, Watts’ emphasis on safety, process automation, and training employees and customers enabled the Company to thrive. Investment in process automation proved pivotal in the wake of pandemic-driven labor shortages and proactive inventory purchases, and vertical integration helped to mitigate supply chain constraints while continuing to serve customers. Watts doubled down on education and training for customers and employees, shifting training offerings to 100% virtual through Watts Works Online and expanding its reach outside the U.S. and into Mexico, Europe, China, and Australia.

In February of 2022, Munish Nanda, president of Americas and Europe, announced his retirement from the Company. Munish successfully led both the Americas and Europe businesses for seven years through many transitions during this period, influencing their strategic direction and growth. In August 2022, Watts welcomed Andre Dhawan as COO (Chief Operating Officer), replacing Nanda.

Opposite: By the end of 2023, Watts was deriving a significant portion of its revenue from smart and connected enabled products. Shown here is a sampling of the commercial connected solutions Watts launched during this time.



Andre Dhawan, COO.



Munish Nanda, president of Americas and Europe announced his retirement in February 2022 after seven years of service to Watts.

Strides in Sustainability

Watts elevated its commitment to sustainability across the entire business during these years. The Company advanced an intentional environmental, social, and governance strategy that formalized its commitment to socially responsible business practices. Integral to this work was the 2021 appointment of general counsel and secretary Kenneth R. Lepage as the Company’s first CSO (Chief Sustainability Officer).

“Although sustainability has been central to Watts’ identity from the very beginning, Watts assessed and acted on new opportunities to deepen its commitments,” said Lepage.

The Company made significant reductions in its water, energy, carbon, and waste footprints across all operations as well as significant advances in disclosures in accordance with global reporting frameworks such as GRI (Global Reporting Initiative), SASB (Sustainability Accounting Standards Board) and UN SDGs (United Nations Sustainable Development Goals).



Kenneth R. Lepage, general counsel, CSO and secretary, shown here volunteering at a Merrimack River cleanup event.

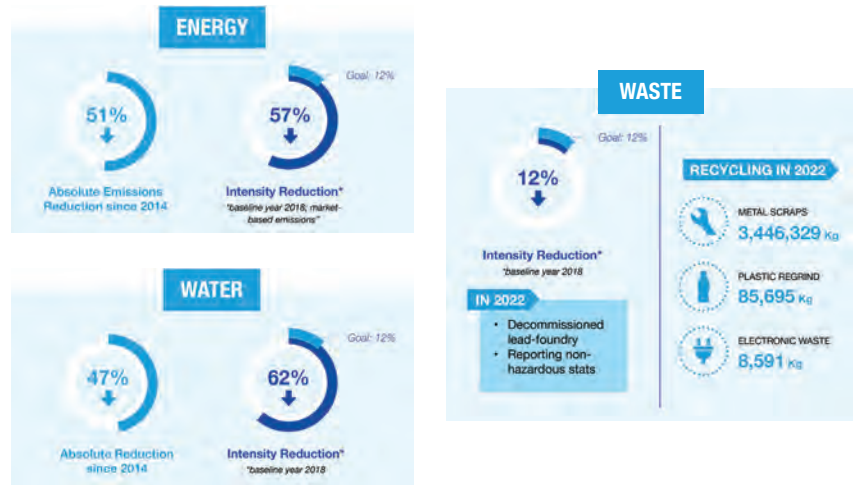

Watts’ performance and reporting efforts led to the Company being recognized by raters and rankers at the top of its peer group:



MSCI “AA” Rating



Sustainalytics “Low Risk” Rating



ISS “Top 3rd Decile” for Industry Group



AERCO Benchmark® Platinum 1000 high-efficiency boiler.



Watts focused on developing and nurturing diverse talent and received recognition for this work.

Each year from 2019-2023, Watts was named by Newsweek as one of America’s Most Responsible Companies and one of America’s Greenest Companies for 2024. In 2023, Watts was also named one of America’s Climate Leaders by USA Today.

Watts heightened its focus on its handprint, or the essential role the Company’s products and solutions have in protecting shared water resources and the people who use and rely on them. The Company continued to develop products and solutions to benefit users and advance sustainability efforts consistent with its vision of a “Triple Play”: safety and regulation, energy efficiency, and water conservation. Examples include the Watts OneFlow® Anti-Scale System; Watts Pressure

Reducing Valves; and AERCO® high-efficiency gas fired boilers and water heaters.

In 2022, Watts became the first company to be verified by The Water Council’s WAVE Water Stewardship program for assessing enterprise-wide water-related risk and taking action to mitigate water-related impact on the environment. Also in 2022, Watts joined the United Nations Global Compact and committed to continuous improvement in water stewardship practice by signing the CEO Water Mandate.

From a social perspective, Watts focused on developing and nurturing diverse talent. In 2020, the Company formed employee resource groups to provide a forum for diverse groups to share

common concerns and experiences, gain professional development support, and engage with leadership. Additionally, in 2022 Watts launched its first global, multi-year leadership and inclusivity training program for all employees. Watts was named one of the Top Places to Work in Massachusetts for 2023 by the Boston Globe.

Underpinning all sustainability-related programming is the OWPS (One Watts Performance System), a global program that helps team members understand operating philosophies and principles. The program empowers all employees to drive meaningful improvements in critical areas that impact customers and operational efficiency.



Smart and Connected Innovation

By the end of 2023, Watts was deriving a significant and increased portion of its revenue from smart and connected enabled products. The Company expanded internal competencies and made strategic acquisitions and investments, devoting more than half of R&D spending to these products with the goal of transforming traditional mechanical products into smart and connected enabled solutions. At the end of 2023, 70% of the Company's new product vitality was coming from smart and connected enabled products.

"We saw a chance to create a new market standard that puts customers in control with accessible, real-time data to optimize performance, conserve critical resources, and promote safety," said Bob Pagano.

Watts eyed leak detection product growth to help owners and managers prevent costly water-based damage. The acquisitions of TDG (The Detection Group) and Sentinel Hydrosolutions added products to Watts' portfolio to detect leaks and minimize catastrophic water damage.

Watts focused on incorporating smart and connected components, including valves, flow meters, and sensors into existing plumbing and heating system products. These advancements were designed to enable owners to take quick action, alerting them in real time to water discharge, performance issues, maintenance needs, and temperature concerns.

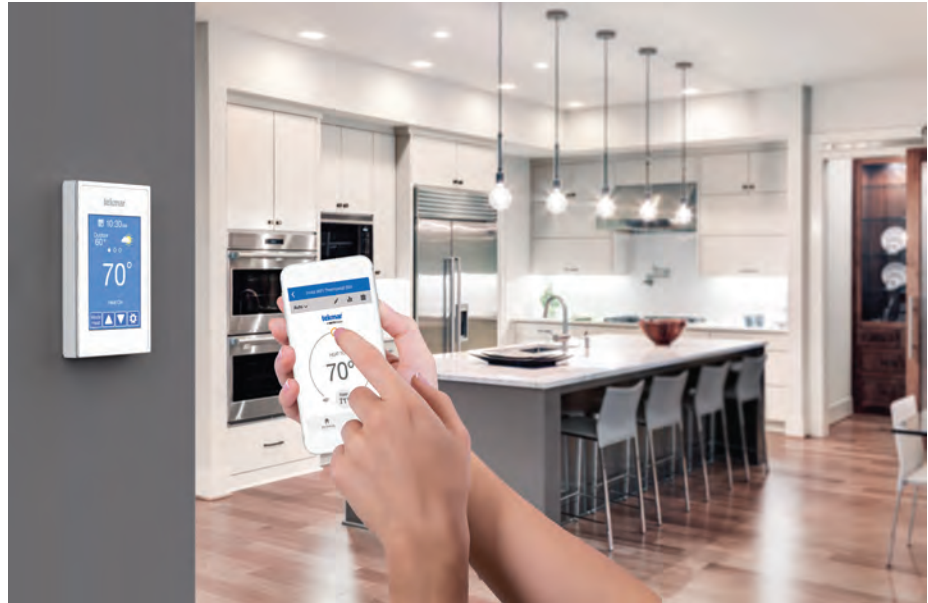

At the end of 2023, 70% of the Company's new product vitality was coming from smart and connected enabled products.



Watts entered the residential and commercial leak detection markets with the acquisitions of The Detection Group and Sentinel Hydrosolutions.



Powers IntelliStation digital mixing system provides more accurate outlet temperatures and remote control & monitoring of tempered water distribution within facilities.



Lync's Aegis heat pumps are one of the cleanest, most efficient, and environmentally friendly ways to heat water.

Product Snapshot

The **Powers IntelliStation**[®] digital mixing system ensures safe, precise, and consistent water temperatures, promoting energy savings and safety.

AERCO Benchmark boilers optimize efficiency and simplify operation with predictive maintenance remote health-of-system monitoring as well as advanced Edge Controller with a mobile app that enables full unit setup and control, enhanced diagnostics, and configuration capabilities.

The **Lync**[®] brand combines water heating, filtration, conditioning and mixing into one system to improve efficiency, safety and water quality while minimizing planning, design, and installation time.

Lync's Aegis[®] electric heat pumps are one of the cleanest, most efficient, and environmentally friendly ways to heat water.

Lync's Element[®] **Q** is one of the world's first hot water wellness solutions with multi-barrier pathogen mitigation.

The **tekmar**[®] **Smart Boiler Control System** enables owners to convert old boiler systems into connected and remotely monitored and controlled boiler systems to reduce operating costs.

The **Watts Vision**[®] system helps homeowners in Europe save energy and improve comfort through greater visibility and control of heating and cooling systems.

The **Intelligent Control Valve** enables building designers, owners, and operators in Asia, the Middle East, and Africa to monitor and control temperature changes and energy consumption in their central air conditioning, heating, and water treatment systems to keep them stable and operational.

Watts also introduced new complementary digital solutions to enhance customer experiences. The Company launched several mobile and web applications, providing building owners, professional service providers, and homeowners greater insight into and control of their products. Additionally, Watts expanded its standalone software solutions including with the 2021 launch in France of Digisco, a cloud-based solution to simplify backflow preventer test management.

As of the end of 2023, Watts is working to develop a solution to provide commercial building owners with a system-wide connected experience offering greater plumbing system visibility.

Seizing Market Opportunities in Australia and New Zealand

Building on momentum from the acquisition of New Zealand-based APEX® Valves, Watts continued its growth in New Zealand and Australia — two highly regulated markets with strong and enforced plumbing codes and high value for water safety and conservation.

In 2020, Watts acquired AVG (Australian Valve Group), a manufacturer of heating and hot water control valves. Then, in 2023, Watts acquired Enware Australia Pty. Limited, a leading supplier of plumbing and safety equipment to a wide variety of commercial industries — most notably healthcare. Together, these acquisitions enabled Watts to provide a comprehensive product package in the Australian and New Zealand markets.

“Watts’ rich legacy in backflow products helped us gain market attention, and then the acquisitions of these highly regarded companies cemented the channel access we needed to grow into a market leader in these regions,” said Elie Melhem, president, Asia-Pacific, the Middle East & Africa.

Watts Expands into Front-of-the-Wall Adjacencies in Americas

October of 2023, Watts acquired Bradley Corporation, a veteran manufacturer of commercial washroom and emergency safety products serving commercial and industrial end markets. The acquisition was strategic for a few reasons: it provided Watts a strong foundation to expand in commercial and industrial markets and enabled the Company to build an industry-leading water application portfolio, adding front-of-wall applications including plumbing fixtures, specialty washroom products and emergency safety products to its differentiated back-of-wall products. In a continuation of the Bradley Corporation’s family-owned legacy, Bryan Mullett continued to serve as Bradley President.



Elvari LED Mirrors from Bradley.



Pedestal-Mount Halo Eye-Face Wash from Bradley.



Looking Forward at Watts' 150 Anniversary

As Watts reached a milestone of achieving \$2 billion in revenue in 2023 and marks its 150 anniversary in 2024, the Company has become an example of an American manufacturing success story. Watts is evolving from its humble beginnings to the position of a global industry leader, all while staying true to core business and values. By understanding and addressing customer needs, staying at the forefront of innovation, constantly looking ahead and pushing the industry forward, Watts will continue to be an iconic leader in the industry for years to come.



