



## PERMEATE PUMP INSTALLATION INSTRUCTIONS



### Warning

Please read carefully before proceeding with installation. Failure to follow attached instructions or operating parameters may lead to the product's failure and possible damage to property

Watts Premier, Inc.  
Phone: 800-752-5582

8716 W Ludlow Drive Suite #1  
[www.wattspremier.com](http://www.wattspremier.com)

Peoria, AZ 85381  
Fax: 623-866-5666

# Package Contents:

Examine the components carefully to make sure no damage has occurred to the Permeate Pump. Care should be taken to ensure the pump is not dropped or mishandled; dropping will damage the pump

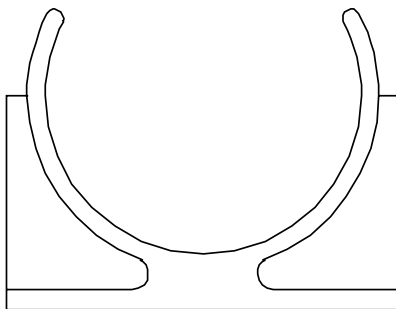
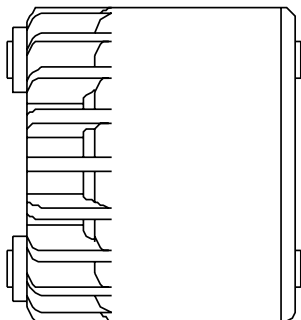

(1) Permeate Pump with mounting clip (P/N 152002)

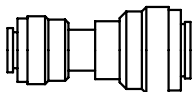

(2) Quick Connect Reducer Union (P/N 125037)

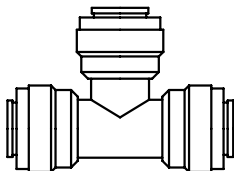

(1) 3/8" Quick Connect Union Tee (P/N 225051)

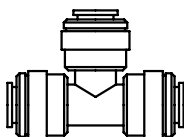

(1) 1/4" Quick Connect Union Tee (P/N 125052)

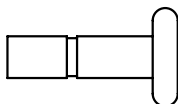

(1) 3/8" Plug Insert (P/N 228073)

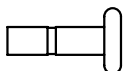

(1) 1/4" Plug Insert (P/N 228266)

Additional Items Not Shown:

(2) 3" long, 1/4" Blue Tubes (P/N 710450)

(1) 48" long, 1/4" Blue Tube (P/N 610113)

# How To Use the Quick Connect Fittings

To make a connection, the tube is simply pushed in by hand; the unique patented John Guest collet locking system then holds the tube firmly in place without deforming it or restricting flow.

## Cut the Tube Square

---



Cut the tube square and remove burrs and sharp edges. Ensure that the outside diameter is free from score marks.

## Push Up to the Tube Stop

---

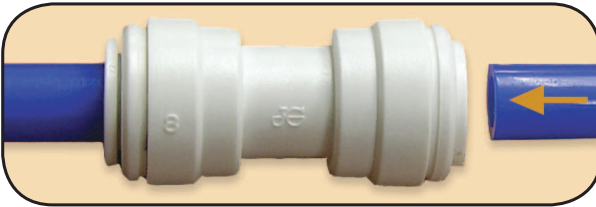

Push the tube into the fitting and up to the tube stop

## Pull to Check Secure

---

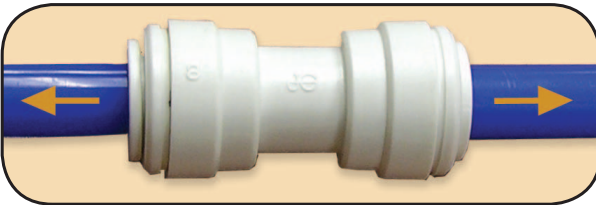

Pull on the tube to check that it is secure. Test the system before use

## To Disconnect

---

Push in collet and remove tube

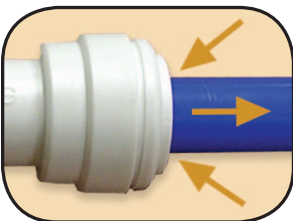

To disconnect, ensure that the system is depressurized, push the collet square against the fitting. With the collet held in this position the tube can be removed.

# Permeate Pump Installation for the Standard System

## Parts Needed:

- (1) Permeate Pump with mounting clip (P/N 152002)
- (1) 48" long, 1/4" Blue Tube (P/N 610113)

NOTE: When mounting the Permeate Pump, make sure the outlet ports of the Permeate Pump are above the inlet ports in order to allow entrapped air to escape

## Installation Steps:

- Step 1 - Turn off the incoming water to the reverse osmosis unit. Lift the handle on the reverse osmosis drinking water faucet to drain the water from the system and storage tank. Note: If tank is equipped with a ball valve, close valve to preserve the tank water.
- Step 2 - Before installing the Permeate Pump, remove the blue tube-inserts from the ports. Refer to the diagram on Page 3 for instructions for disconnecting tubes from a quick-connect fitting
- Step 3 - Cut the blue tube between the shut-off-valve and the reverse osmosis membrane. Then insert that blue tube from the membrane into the Permeate Pump "PERMEATE IN" port. Use the additional blue tubing if extra length is needed
- Step 4 - Insert the tube from the shut-off-valve into the Permeate Pump "PERMEATE OUT" port. Use the additional blue tubing if extra length is needed.
- Step 5 - Cut the 1/4" waste line from the membrane (after the flow restrictor) and then insert the tube from the membrane into the Permeate Pump "BRINE IN" port (Make sure the flow restrictor is located between the Permeate Pump and the membrane)
- Step 6 - Insert the 1/4" red tube from the faucet air gap inlet into the Permeate Pump "BRINE OUT" port
- Step 7 - Make sure your installation matches the diagram shown in Figure 1
- Step 8 - Turn on the water supply. Check for leaks periodically for the next 24-48 hours as the system fills and again after it shuts off when the tanks is full.

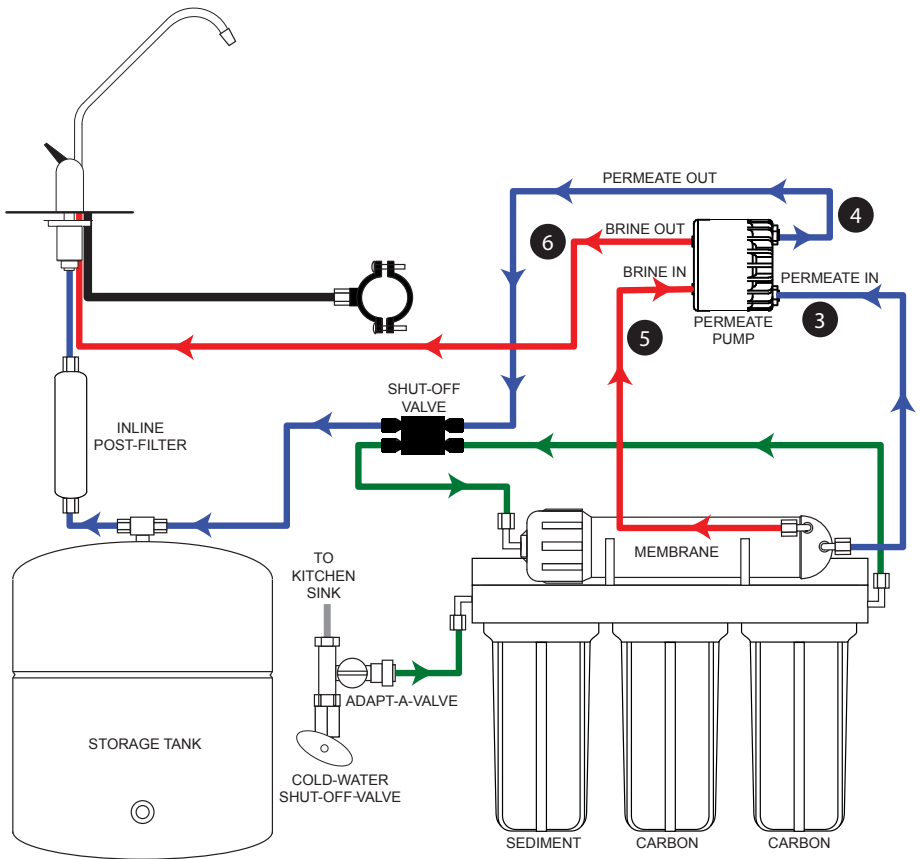

Figure 1: Standard System after installation of Permeate Pump

# Permeate Pump Installation for the Manifold System

## Parts Needed:

- (1) Permeate Pump with mounting clip (P/N 152002)
- (2) Quick Connect Reducer Union (P/N 125037)
- (2) 3" long, 1/4" Blue Tubes (P/N 710450)
- (1) 3/8" Quick Connect Union Tee (P/N 225051)
- (1) 3/8" Plug Insert (P/N 164027)

NOTE: The Permeate Pump is equipped with 1/4" Quick Connect push-to-connect fittings. The pump can be used in RO systems with 3/8" tubing by inserting a short piece of 1/4" tubing into the port on the Permeate Pump and attaching a Quick Connect Reducer Union to the tubing. Also, when mounting the Permeate Pump, make sure the outlet ports of the Permeate Pump are above the inlet ports in order to allow entrapped air to escape

## Installation Steps:

- Step 1 - Turn off the incoming water to the reverse osmosis unit. Lift the handle on the reverse osmosis drinking water faucet to drain the water from the system and storage tank. Note: If tank is equipped with a ball valve, close valve to preserve the tank water.
- Step 2 - Before installing the Permeate Pump, remove the blue tube-inserts from the ports. Refer to the diagram on Page 3 for instructions for disconnecting tubes from a quick-connect fitting.
- Step 3 - Remove the 3/8" blue tube from the manifold "TANK" port and insert the 3/8" Plug
- Step 4 - Locate the 3/8" blue tube from the manifold "FAUCET" port and cut approximately 24" from the manifold and re-route into the Permeate Pump "PERMEATE IN" port using a Reducer Union and a 3" long, 1/4" blue tube
- Step 5 - Insert the 3/8" blue tube from the faucet into the Permeate Pump "PERMEATE OUT" port using a Reducer Union and a 3" long, 1/4" blue tube
- Step 6 - Locate the 3/8" blue tube between the faucet and Permeate Pump, and then cut and insert the 3/8" Union Tee.
- Step 7 - Insert the 3/8" blue tube leading to the tank into the open port of the 3/8" Union Tee
- Step 8 - Locate the 1/4" red tube between the manifold "DRAIN" port and the faucet air gap inlet and then cut the tube 24" from the manifold (Making sure to leave the flow restrictor plugged into the manifold) Insert the red tube from the manifold into the Permeate Pump "BRINE IN" port and the red tube from the faucet into the Permeate Pump "BRINE OUT" port.
- Step 9 - Make sure your installation matches the diagram shown in Figure 2
- Step 10 - Turn on the water supply. Check for leaks periodically for the next 24-48 hours as the system fills and again after it shuts off when the tanks is full

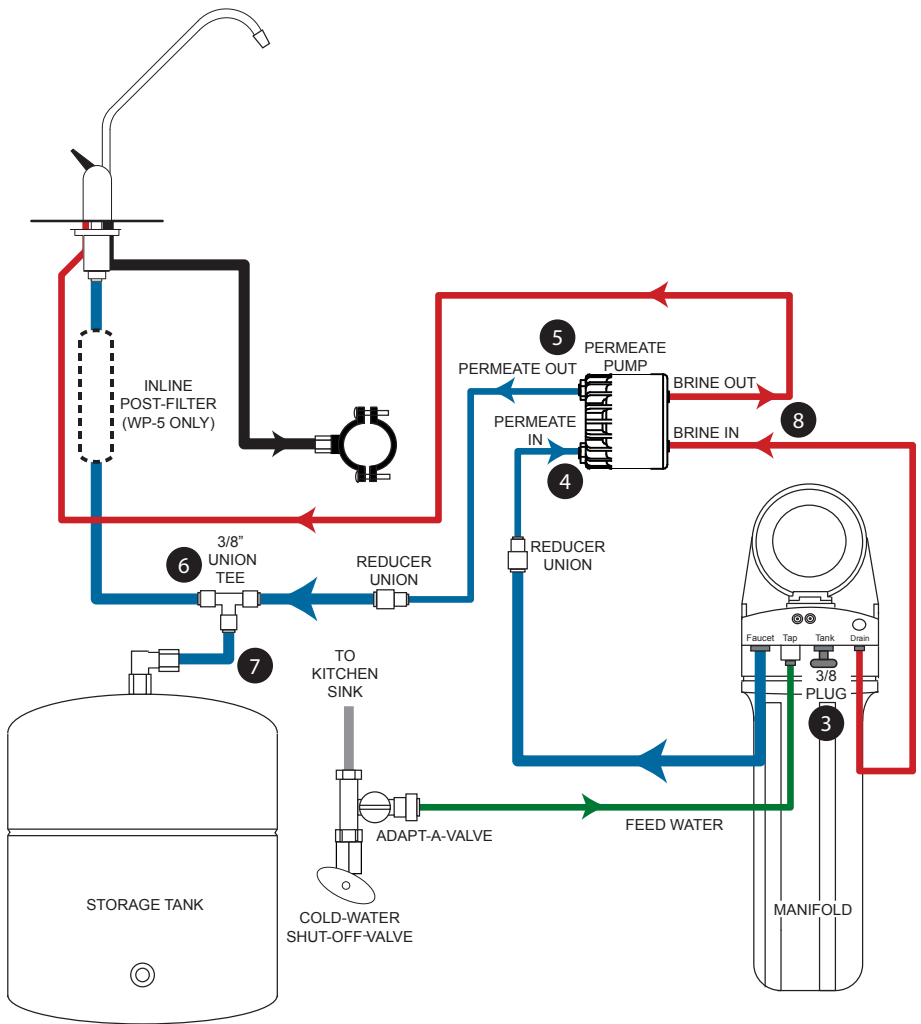

Figure 2: Manifold System after installation of Permeate Pump

# Permeate Pump Installation for the RO Pure

## Parts Needed:

- (1) 1/4" Plug Insert (P/N 228266)
- (1) 1/4" Quick Connect Union Tee (P/N 125052)
- (1) 48" long, 1/4" Blue Tube (P/N 610113)
- (1 - Optional) Inline Post Filter (P/N 560010)

NOTE: When mounting the Permeate Pump, make sure the outlet ports of the Permeate Pump are above the inlet ports in order to allow entrapped air to escape

## Installation Steps:

- Step 1 - Turn off the incoming water to the reverse osmosis unit. Lift the handle on the reverse osmosis drinking water faucet to drain the water from the system and storage tank. Note: If tank is equipped with a ball valve, close valve to preserve the tank water.
- Step 2 - Before installing the Permeate Pump, remove the blue tube-inserts from the ports. Refer to the diagram on Page 3 for instructions for disconnecting tubes from a quick-connect fitting
- Step 3 - Locate the blue tube coming out of the elbow above the blue filter, then cut the tube 24" from the filters and insert the blue tube into the Permeate Pump "PERMEATE IN" port
- Step 4 - Remove the blue tube from the elbow behind the green filter and insert a 1/4" plug into the elbow.
- Step 5 - Insert the blue tube from the shut-off-valve into the Permeate Pump "PERMEATE OUT" port. Use the additional blue tubing if extra length is needed.
- Step 6 - Cut the blue tube between the tank and shut-off-valve and install a 1/4" quick connect union tee
- Step 7 - Insert the blue tube leading to the faucet into 1/4" quick connect union tee
- Step 8 - Locate the 1/4" red drain tube between the filters and faucet, and then cut the tube 24" from the filters.
- Step 9 - Insert the 1/4" red drain tube, from the filters, into the Permeate Pump "BRINE IN" port.
- Step 10 - Insert the 1/4" red drain tube, from the faucet, into the Permeate Pump "BRINE OUT" port
- Step 11 - Make sure your installation matches the diagram shown in Figure 3
- Step 12 - (Optional) Locate the 1/4" blue tube between the faucet and quick connect union tee and install the inline post filter.



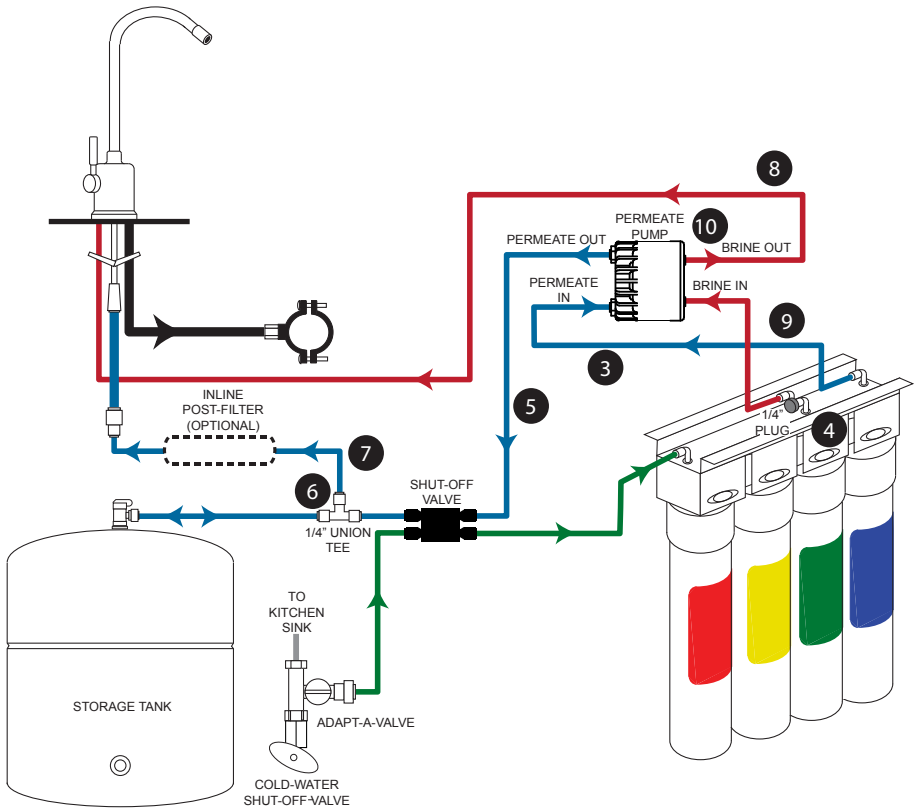

Figure 3: RO Pure after installation of Permeate Pump

This Page Intentionally Left Blank



